

REGULAR BOARD MEETING AGENDA - JANUARY 4, 2010 - 7:30 P.M.

1. Call to Order
2. Pledge of Allegiance
3. Roll Call
4. Minutes of Previous Meeting
 - 4 - 1. December 21, 2009 - Regular Board Meeting - **Exhibit A**
5. Finance
 - 5 - 1. Finance Committee Meeting - Wednesday, December 30, 2009 - 4:00 p.m. - **Exhibit B**

5 - a. Board Report - MFT:	\$	0.00
5 - b. Board Report - General:	\$	404,544.04
5 - c. Warrant List - MFT Approve Payment for:	\$	0.00
5 - d. Warrant List - General Approve Payment for:	\$	67,426.11
5 - e. Warrant List - Total Approve Payment for:	\$	67,426.11
 - 5 - 2. FY02 Audit - **Exhibit C**
6. Treasurer's Report - None.
7. Attorney's Report - None.
8. ESDA Report -
9. Public Participation -
 - 9 - 1. Andrew Lehman
10. Reports and Correspondence -
 - 10 - 1. Freeburg High School Athletic Teams Proclamation - **Exhibit D**
11. Recommendations of Boards and Commissions - None.
12. Contracts, Releases, Agreements and Annexations -
 - 12 - 1. See Ordinance No. 1342 - Ron Waters Annexation - **Exhibit F**
13. Bids - None.
14. Resolutions - None.
15. Ordinances -
 - 15 - 1. Ordinance No. 1341: Tax Abatement Ordinance - **Exhibit E**
 - 15 - 2. Ordinance No. 1342: Ordinance Authorizing Execution of Waters Annexation Agreement - **Exhibit F**
 - 15 - 3. Ordinance No. 1343: Ordinance Annexing Waters Property - **Exhibit G**
16. Old Business
17. New Business
18. Appointments
19. Committee Meeting Minutes - None.
20. Upcoming Meetings
 - 20 - 1. Legal/Ordinance Committee Meeting - Wednesday, January 6, 2010 - 4:30 p.m.
 - 20 - 2. Electric Committee Meeting - Wednesday, January 13, 2010 - 5:30 p.m.
 - 20 - 3. Personnel/Police Committee Meeting - Wednesday, January 13, 2010 - 6:30 p.m.
 - 20 - 4. CLOSED IN OBSERVANCE OF MARTIN LUTHER KING DAY - Monday, January 18th
 - 20 - 5. Board Meeting - Tuesday, January 19, 2010 - 7:30 p.m.
21. Village President's and Trustees' Comments
22. Staff Comments
23. Adjournment

At said Board Meeting, the Village Board of Trustees may vote on whether or not to hold an Executive Session to discuss the selection of a person to fill a public office [5 ILCS, 120/2 - (c)(3)]; personnel [5 ILCS, 120/2 - (c)(1)a.]; litigation [5 ILCS, 120/2 - (c)(11)]; real estate transactions [5 ILCS, 120/2 - (c)(5)].

VILLAGE PRESIDENT
Ray Danford

VILLAGE CLERK
Jerry Menard

VILLAGE TRUSTEES
Corby Valentine
Steve Smith
Tony Miller
Rita Baker
Seth Speiser
Charlie Mattern

VILLAGE OF FREEBURG

FREEBURG MUNICIPAL CENTER
14 SOUTHGATE CENTER, FREEBURG, IL 62243
PHONE: (618) 539-5545 • FAX: (618) 539-5590
Web Site: www.freeburg.com

FREEBURG REGULAR BOARD MEETING Monday, December 21, 2009 at 7:30 P.M. Board Minutes

EXHIBIT A
VILLAGE ADMINISTRATOR
Dennis Herzing

VILLAGE TREASURER
Bryan A. Vogel

PUBLIC WORKS DIRECTOR
Ronald Dintelmann

POLICE CHIEF
Melvin E. Woodruff, Jr.

VILLAGE ATTORNEY
Stephen R. Wigginton

CALL TO ORDER: Acting Mayor Rita Baker called the Regular Board Meeting to order at 7:30 p.m., on Monday, December 21, 2009 in the Freeburg Municipal Board Room.

PLEDGE OF ALLEGIANCE: Those present and Board Members recited the Pledge of Allegiance.

ROLL CALL: Trustee Charlie Mattern – here; Trustee Steve Smith – here; Trustee Rita Baker – here; Trustee Corby Valentine – here; Trustee Tony Miller – here; Trustee Seth Speiser – here and Mayor Raymond Danford – absent; (6 present, 1 absent). Acting Mayor Rita Baker announced there is a quorum.

MINUTES OF PREVIOUS MEETING: *Trustee Tony Miller motioned to approve the minutes of Monday, December 7, 2009 and Trustee Steve Smith seconded the motion; (6 ayes, 0 nays, 0 absent). All voting aye, the motion carried.*

FINANCE: Trustee Steve Smith said he gave the audit report to everyone to look at and review and vote on it at the next board meeting.

TREASURER'S REPORT: Acting Mayor Baker said Treasurer Bryan Vogel is not present this evening.

ATTORNEY'S REPORT: Acting Mayor Baker announced that we will not go into Executive Session this evening. Village Administrator Dennis Herzing said we will be putting this back on the agenda for the January meeting.

ESDA REPORT: Acting Mayor Baker said our ESDA Coordinator Gene Kramer is not present this evening.

PUBLIC PARTICIPATION: Acting Mayor Baker asked if anyone would like to take the floor. Janet said the Freeburg Women's Club would like to make a \$25.00 donation to the Christmas Lights Fund.

REPORTS AND CORRESPONDENCE: Acting Mayor Baker said we have a letter from St. John the Baptist School asking for a donation for their 10th Annual Dinner Auction.

Trustee Tony Miller motioned to donate a 10-day swimming pass to St. John the Baptist School Annual Dinner Auction and Trustee Corby Valentine seconded the motion.

ROLL CALL: Trustee Tony Miller – aye; Trustee Corby Valentine – aye; Trustee Charlie Mattern – aye; Trustee Steve Smith – aye; Trustee Rita Baker – aye; Trustee Seth Speiser – aye; (6 ayes, 0 nays, 0 absent). All voting aye, the motion carried.

RECOMMENDATIONS OF BOARDS AND COMMISSIONS: None.
CONTRACTS, RELEASES, AGREEMENTS AND ANNEXATIONS: None.
BIDS: None

RESOLUTIONS: Acting Mayor Baker said next is Resolution #09-13: A Resolution Authorizing a Representative to Sign Loan Documents.

Trustee Charlie Mattern motioned to adopt Resolution #09-13 by title only and Trustee Tony Miller seconded the motion. ROLL CALL: Trustee Charlie Mattern – aye; Trustee Tony Miller - aye; Trustee Seth Speiser - aye; Trustee Corby Valentine – aye; Trustee Steve Smith – aye; Trustee Rita Baker – aye; (6 ayes, 0 nays, 0 absent). All voting aye, the motion carried.

Acting Mayor Baker said next is Resolution #09-14: A Resolution of Intent Regarding National Flood Insurance.

Trustee Charlie Mattern motioned to adopt Resolution #09-14 by title only and Trustee Tony Miller seconded the motion. ROLL CALL: Trustee Charlie Mattern – aye; Trustee Tony Miller - aye; Trustee Seth Speiser - aye; Trustee Corby Valentine – aye; Trustee Steve Smith – aye; Trustee Rita Baker – aye; (6 ayes, 0 nays, 0 absent). All voting aye, the motion carried.

ORDINANCES: Acting Mayor Baker said next on the agenda is Ordinance No. 1339: An Ordinance Annexing Certain Territory Commonly Known as the “Mueth Property” to and in the Village of Freeburg, St. Clair County, Illinois.

Trustee Tony Miller motioned to adopt Ordinance No. 1339 by title only and Trustee Corby Valentine seconded the motion. ROLL CALL: Trustee Tony Miller – aye; Trustee Corby Valentine - aye; Trustee Rita Baker - aye; Trustee Steve Smith – aye; Trustee Seth Speiser – aye; Trustee Charlie Mattern – aye; (6 ayes, 0 nays, 0 absent). All voting aye, the motion carried.

Acting Mayor Baker said next is Ordinance No. 1340: An Ordinance Annexing Certain Territory Commonly Known as the “Wilkerson Property” to and in the Village of Freeburg, St. Clair County, Illinois.

Trustee Tony Miller motioned to adopt Ordinance No. 1340 by title only and Trustee Corby Valentine seconded the motion. ROLL CALL: Trustee Tony Miller – aye; Trustee Corby Valentine - aye; Trustee Rita Baker - aye; Trustee Steve Smith – aye; Trustee Seth Speiser – aye; Trustee Charlie Mattern – aye; (6 ayes, 0 nays, 0 absent). All voting aye, the motion carried.

ESDA REPORT: Acting Mayor Baker called on our ESDA Coordinator Gene Kramer. Gene brought us up to date on the weather and what we can expect for the next couple of days. Gene said area residents who are interested in getting the H1N1 shot will be able to do so locally at Freeburg’s vaccination clinic. Gene said the clinic will be open on January 9, 2010 at 9:00 a.m. to 1:00 p.m., at the Freeburg Elementary School. Gene said the vaccine will be available free of charge, to all age groups over six months of age. Gene said anyone under the age of 18 years must have their parent or

legal guardian present.

Gene also reminded us starting on January 1, 2010 the "Illinois New Cell Phone Rules Become Law." This means you no longer will be able to text while driving or using cell phone in school speed zones.

OLD BUSINESS: Acting Mayor Rita Baker called for any old business at this time.

Trustee Steve Smith asked if we have the proclamation to honor the State Champion Girl's volleyball team and the other sports done yet and Dennis replied we are working on it.

NEW BUSINESS: None.

APPOINTMENTS: None.

COMMITTEE MEETINGS MINUTES:

Electric Committee Meeting: Trustee Corby Valentine called the Electric Committee Meeting to order on Wednesday, December 9, 2009 at 5:30 p.m.

1. **Switchover of Ameren to Freeburg:** Trustee Valentine said we discussed the switchover from Ameren to Freeburg power. Trustee Valentine said Ameren offered to sell their facilities to us at a cost of \$300,000. We gave it to our engineering firm to do the analysis on it to see if the numbers they used were correct. There are some questions about copper verses aluminum. When they said they used copper, the engineer that is working on our request actually worked for Ameren back then. We are going to get that cleared up. It won't make a big difference in the final number. As soon as we get that back and get a final cost, it will come out of the committee to the board.

2. **Three-phase Customer:** Trustee Valentine said we talked about the three-phase power service fees and we have a couple of questions for the attorney.

Public Works Committee Meeting: Trustee Charlie Mattern called Public Works Committee Meeting to order on Wednesday, December 16, 2009 at 5:30 p.m.

1. **Sewer Project:** Trustee Mattern said we got an update on the sewer project from Larry Rhutasel and will be passing the resolution this evening authorizing the Mayor to sign the necessary documents for the loan applications.

2. **SAVE Site Water Situation:** Trustee Mattern said we got an update on the Save water situation. We are waiting for the release from the St. Clair County Grants Department.

3. **Recycling:** Trustee Mattern said the recycling is doing very well-at least for the first couple of weeks. Dennis said it is still doing very well. Trustee Mattern asked how the turnout was for the Township on Saturday. Dennis said he was not there, but we had two dumpsters and they were stuffed when he got here Monday morning. Trustee Mattern said on behalf of the rest of the committee

and the board, he would like to thank everybody in town for bearing with us as we made that transition. It seems to working quite well.

4. **Sewer Backup Policy:** Trustee Mattern said we are going to take some measures to eliminate some sewer backup problems on Main Street pending completion of the project Rhutasel is working on. At this time, Trustee Mattern said he would like to make a motion.

Trustee Charlie Mattern motioned to authorize the Public Works Department to install a temporary lift station on North State Street not to exceed \$15,000 and Trustee Tony Miller seconded the motion. ROLL CALL: Trustee Charlie Mattern – aye; Trustee Tony Miller - aye; Trustee Seth Speiser - aye; Trustee Corby Valentine – aye; Trustee Steve Smith – aye; Trustee Rita Baker – aye; (6 ayes, 0 nays, 0 absent). All voting aye, the motion carried.

5. **FSH System:** Trustee Mattern said we are proceeding with making modifications to our connection with FSH to improve the water services to the village by being able to access all the water that is in the FSH tower just outside of town.

Public Property Committee Meeting: Trustee Tony Miller called the Public Property Committee Meeting to order on Wednesday, December 16, 2009 at 6:30 p.m.

1. **Pool:** Trustee Miller asked Dennis if he called Bill Reichert. Dennis said no, not yet. Trustee Miller said we talked about the job descriptions for the managers for the pool and we have come up with a plan. Trustee Miller said that John, Dennis, Julie and Ron are working on a list. Tony talked to Scott, and he does plan on coming back. Trustee Miller said we also discussed the lifeguards and we will take care of that also. Trustee Miller said letters are going out to our past lifeguards over the holidays while some of the college students are home.

2. **Street Safe Routes To School:** Trustee Miller said we discussed the Safe Routes. Trustee Miller said Dennis was going to make a phone call to IDOT. Dennis said the guy he needs to talk to is out for the rest of the week.

3. **Cemetery Road:** Trustee Miller said we still have not heard back on this.

4. **Street Banners:** Trustee Miller said we have four people who are purchasing a banner for next year.

UPCOMING MEETINGS:

1. CLOSED IN OBSERVANCE OF CHRISTMAS - December 24th and December 25th
2. Finance Committee Meeting - Wednesday, December 30, 2009 - 4:00 p.m.
3. Economic Development Committee Meeting – Monday, December 30, 2009 – 6:30 p.m.(CANCELLED)
4. CLOSED IN OBSERVANCE OF NEW YEARS DAY - Friday, January 1, 2010
5. Board Meeting – Monday, January 4, 2010 – 7:30 p.m.

VILLAGE PRESIDENTS AND TRUSTEE'S COMMENTS

Trustee Seth Speiser: No, thank you.

Trustee Tony Miller: Merry Christmas everyone and on the proclamations he would like to have that set up for the January 4th meeting and invite a representative from each of the sports. Trustee Miller asked if anyone would like to add anything to this. Trustee Smith said he agrees we should do this and it should have been done already.

Trustee Corby Valentine: Merry Christmas to everyone.

Acting Mayor and Trustee Rita Baker: Merry Christmas.

Trustee Steve Smith: Merry Christmas and best wishes for the New Year.

Village Clerk Jerry Menard: Merry Christmas and Happy New Year. Village Clerk asked is everyone going to be here at the January 4th meeting. We are going to get our picture taken, if possible.

STAFF: None.

ADJOURN:

Trustee Tony Miller motioned to adjourn at 7:51 p.m. and Trustee Corby Valentine seconded the motion. All voting aye, motion carried.

Jerry Lynn Menard,
Village Clerk

VILLAGE PRESIDENT
Ray Danford

VILLAGE CLERK
Jerry Menard

VILLAGE TRUSTEES
Corby Valentine
Steve Smith
Tony Miller
Rita Baker
Seth Speiser
Charlie Mattern

VILLAGE OF FREEBURG

FREEBURG MUNICIPAL CENTER
14 SOUTHGATE CENTER, FREEBURG, IL 62243
PHONE: (618) 539-5545 • FAX: (618) 539-5590
Web Site: www.freeburg.com

Finance Committee Meeting
(Finance/Industrial Park/Economic Development/Budget)
Smith/Valentine/Speiser

Wednesday, December 30, 2009 at 4:00 p.m.

EXHIBIT B
VILLAGE ADMINISTRATOR
Dennis Herzing

VILLAGE TREASURER
Bryan A. Vogel

PUBLIC WORKS DIRECTOR
Ronald Dintelmann

POLICE CHIEF
Melvin E. Woodruff, Jr.

VILLAGE ATTORNEY
Stephen R. Wigginton

Chairperson Steve Smith officially called the meeting of the Finance Committee to order at 4:00 p.m. on Wednesday, December 30, 2009. Those in attendance were Chairperson Steve Smith, Trustee Corby Valentine, Trustee Seth Speiser, Village Administrator Dennis Herzing and Office Manager Julie Polson. Guest present: Bill Schmaltz.

Trustee Corby Valentine motioned to amend the agenda so guest Bill Schmaltz could go first and Trustee Seth Speiser seconded the motion. All voting, aye the motion carried.

4. Health Insurance Renewal: Bill explained they have new software in place that will store all the applicant's medical information and can be sent out to several different carriers, rather than having the employee fill out an application for each carrier. We have three carriers we can work with since we have a retiree in the plan--Blue Cross Blue Shield, GHP and United Healthcare. Both GHP and United Healthcare's premium quote were too high to be considered. Bill advised the committee they are a consulting firm and not a broker so they go out and try to find the best priced product for our group. He provided a spreadsheet of the renewal premium as well as the quotes from GHP and UHC. Our renewal premium with BCBS went from \$17,030.37 to \$21,042.18. He provided additional quotes from BCBS of a \$2500/100% combined deductible at \$19,063.69 per month; and a \$2,500/80% embedded deductible at \$17,474.00. With our current plan, the embedded deductible means once an individual spends \$2,500 of his deductible, all medical expenses will be covered at 100% by BCBS. For anyone other than on individual coverage, once the next family member on the plan spends \$2,500, all remaining expenses for the family would be covered at 100% by BCBS. If we go to a combined deductible, once the \$5,000 limit has been met for any plans other than individual coverage, all family members would be reimbursed at 100% by BCBS. The premium savings with the combined plan would be \$23,741.88. Julie advised the committee Barb did not continue her insurance through the Village so \$632.16 can be deducted from the monthly premium. Dennis reminded the committee Rich will be retiring in March of 2010 and the monthly premium can be reduced by \$310.73 at that time. With the premium deductions, the renewal premium per month would be \$20,099.29 and the yearly cost to renew with the same plan decreased from \$48,141.72 to \$36,827.04. Seth said with the current plan, the deductibles are reimbursed at 100% and if you go to the 80%, either they are going to pay the 20% or the city will. Dennis said if you go with the combined deductible, the risk is on the village. You would save the \$20,000 in premium, but the question is how much will you eat up in reimbursing.

Finance Committee Minutes
Wednesday, December 30, 2009
Page 1 of 3

deductibles. We can't predict how much money that would be. The committee discussed the new state law that went into effect on June 1, 2009 where dependent children can be kept on the parent's insurance policy until the age of 26 without the requirement of being a full-time student. They do not have to live at home and do not have to be claimed as a dependent, however they must remain unmarried. For us, it will go into effect with our renewal at January 1, 2010. Bill said maybe you can change your policy to not pay for the dependent but not deny them from being on the plan. Corby thinks if the dependent hits a certain age and should be out of school, the village shouldn't have to pay their premium. He thinks they should be a student, prove it, and live under the parent's roof. We will look to see if we have any families in that situation. Corby asked if we have anything in place that the employee signs when the spouse is covered by their own policy. Dennis thinks we had this discussion a couple of years ago and Wigginton told us we have to treat everyone the same even though they have the opportunity to get insurance somewhere else. The committee agreed to a policy where a spouse is covered by their own insurance policy, an EOB must accompany the request for reimbursement. The committee discussed the different options and agreed to remain with the current plan.

A. REVIEW OF BOARD AND WARRANT LIST: The Board Lists and Warrant List were reviewed by the committee. Corby questioned the \$150 payment to Billie and Julie advised it was reimbursement for the Christmas decorations at the first annual Christmas Lighting event. Seth asked about the snow removal expense and Dennis advised we bought salt. Steve asked about the Hodge Dwyer Driver expense and Dennis advised that was the legal fee for the air permit.

Trustee Corby Valentine motioned to recommend to the full Board approval of the Warrant List in the amount of \$67,426.11 and Trustee Seth Speiser seconded the motion. All voting aye, the motion carried.

B. REVIEW OF INVESTMENTS: Steve commented we have cd's coming due in March.

C. INCOME STATEMENT: Steve asked Julie for an updated amount on the Christmas lights donations and if we have money left over to try and put it in a cd. Steve asked about what 53-00-367 is and Dennis said that is for meter supplies and labor.

D. TREASURER'S REPORT: None.

E. OLD BUSINESS:

1. Approval of December 2, 2009 minutes: *Trustee Seth Speiser motioned to approve the December 2, 2009 minutes and Trustee Corby Valentine seconded the motion. All voting aye, the motion carried.*

2. Attorney Invoices: The invoices were reviewed by the committee.
3. Sales tax - TIF: Dennis advised we have received the sales tax report from the Illinois Department of Revenue for the first three quarters of 2009. It is running about \$20,000 per quarter. Dennis said we need to send about \$65,000 to Commerce Bank. Item can be taken off the agenda.
4. Health insurance renewal: See above.
5. 3-to5- year plan: Steve will update a couple of items and get a Committee as a Whole meeting scheduled in February. Corby said he would like to discuss the tax levy at that meeting and have someone there to help educate us on it. Dennis thinks it might be a little too early to do that and would like to work on the budget prior to that. The tax levy will be placed on the finance agenda.
6. FY09 Audit: The committee was okay with the audit and it will be put on the agenda for Monday's board meeting.

Trustee Corby Valentine motioned to present the FY09 Audit to the full Board for approval and Trustee Seth Speiser seconded the motion. All voting aye, the motion carried.

F. NEW BUSINESS:

1. Tax Abatement Ordinance: Dennis said we abate the taxes on the bonds for the power plant. If we don't abate them, everyone's taxes would triple.

Trustee Seth Speiser motioned to recommend the Tax Abatement Ordinance be presented to the full Board for their approval and Trustee Corby Valentine seconded the motion. All voting aye, the motion carried.

Dennis advised that he has been reviewing the budget and the biggest hit to revenue he sees coming is going to be from state income tax and thinks it will decrease by 32% from what we budgeted or approximately \$247,000. He does not think we will be in any great big trouble. We do have items in the budget that we budgeted for but have not spent. He also said the sales tax looks to be close to what we budgeted.

G. PUBLIC PARTICIPATION: See above.

H. ADJOURN: *Trustee Corby Valentine motioned to adjourn the meeting at 5:33 p.m. and Trustee Seth Speiser seconded the motion. All voting aye, the motion carried.*

Julie Polson
Office Manager



Finance Committee Meeting
Wednesday, December 30, 2009
Review of Board and Warrant Lists

Review of Board List:

Board List - MFT:	\$ 0.00
Board List - General:	<u>\$ 404,544.04</u>
 Total Board List:	 <u><u>\$ 404,544.04</u></u>

Review of Warrant List:

Warrant List – MFT Approve Payment for:	\$ 0.00
Warrant List - General Approve Payment for:	<u>\$ 67,426.11</u>
	 <u><u>\$ 67,426.11</u></u>

GRAND TOTAL:	<u>\$ 471,970.15</u>
---------------------	-----------------------------



VILLAGE OF FREEBURG, ILLINOIS

FINANCIAL STATEMENTS AND
SUPPLEMENTARY INFORMATION

FOR THE YEAR ENDED
MARCH 31, 2009

233 East Center Drive
P.O. Box 416
Alton, Illinois 62002
(618) 465-7717 St. Louis (314) 355-2586
Fax (618) 465-7710



One Westbury Drive
Suite 420
St. Charles, Missouri 63301-2567
(636) 723-7611 St. Louis (636) 947-1008
Fax (636) 947-4558



C. J. SCHLOSSER
& COMPANY, L.L.C.
CERTIFIED PUBLIC ACCOUNTANTS

J. Terry Dooling
David L. Kamler
David M. Bartosiak
Cindy A. Tefteller
Kevin J. Tepen

INDEPENDENT AUDITOR'S REPORT

To the Honorable Mayor and Board
of Trustees of the Village of
Freeburg, Illinois:

We have audited the accompanying financial statements of the governmental activities, the business-type activities, each major fund and the non-major fund information of the Village of Freeburg, Illinois as of and for the year ended March 31, 2009, which collectively comprise the Village's basic financial statements as listed in the table of contents. These financial statements are the responsibility of the Village's administration. Our responsibility is to express an opinion on these financial statements based on our audit.

We conducted our audit in accordance with auditing standards generally accepted in the United States of America. Those standards require that we plan and perform the audit to obtain reasonable assurance about whether the financial statements are free of material misstatement. An audit includes examining, on a test basis, evidence supporting the amounts and disclosures in the financial statements. An audit also includes assessing the accounting principles used and significant estimates made by the administration, as well as evaluating the overall financial statement presentation. We believe that our audit provides a reasonable basis for our opinion.

As described more fully in Note 1, the Village of Freeburg, Illinois prepares its financial statements on the modified cash basis, which is a comprehensive basis of accounting other than accounting principles generally accepted in the United States of America, except for the Village's Proprietary Funds, which have been prepared on the accrual basis of accounting.

In our opinion, the financial statements referred to above present fairly, in all material respects, the respective financial position of the governmental activities (modified cash basis), the business-type activities (accrual basis), each major fund and the non-major fund information of the Village of Freeburg, Illinois, as of March 31, 2009, and the respective changes in financial position (Governmental activities - modified cash basis, Business-type activities - accrual basis) thereof for the year then ended in conformity with the basis of accounting described in Note 1.

233 East Center Drive
P.O. Box 416
Alton, Illinois 62002
(618) 465-7717 St. Louis (314) 355-2586
Fax (618) 465-7710



PCPS
THE AICPA ALLIANCE FOR CPA FIRMS
www.cjsco.com

One Westbury Drive
Suite 420
St. Charles, Missouri 63301-2567
(636) 723-7611 St. Louis (636) 947-1008
Fax (636) 947-4558

MANAGEMENT'S DISCUSSION AND ANALYSIS

This section of the Village of Freeburg, Illinois' (Village) annual audit presents a management's discussion and analysis of the Village's financial activity during the fiscal year ended March 31, 2009. The Management's Discussion and Analysis (MD&A) is designed to focus on current activities, resulting changes and currently known facts and should be read in conjunction with the basic financial statements and footnotes. Responsibility for the completeness and fairness of this information rests with the Village.

OVERVIEW OF THE FINANCIAL STATEMENTS

This Management's Discussion and Analysis is intended to serve as an introduction to the Village's basic financial statements. There are three components to the basic financial statements:

1. Government-wide financial statements
2. Fund financial statements
3. Notes to the basic financial statements

This report also contains required supplementary information in addition to the basic financial statements.

GOVERNMENT-WIDE FINANCIAL STATEMENTS

The government-wide financial statements are designed to provide readers with a broad overview of the Village's finances, in a manner similar to a private-sector business. The government-wide financial statements exclude any fiduciary fund activities.

The government-wide financial statements distinguish functions of the Village that are principally supported by taxes and intergovernmental revenues (governmental activities) from other functions that are intended to recover all or a significant portion of their costs through user fees and charges (business-type activities). The governmental activities of the Village include general government, public safety, highways and streets, sanitation and development. The business-type activities include water, sewer, electric light and power, and swimming pool.

The statement of net assets presents information on all of the Village's assets and liabilities, with the difference between the two reported as net assets. Over time, increases or decreases in net assets may serve as a useful indicator of whether the financial position of the Village is improving or deteriorating.

The statement of activities presents information showing how the Village's net assets changed during the most recent fiscal year. Changes in net assets are reported on the modified cash basis of accounting for the governmental activities and the accrual basis of accounting for the business-type activities.

GOVERNMENT-WIDE FINANCIAL ANALYSIS

The Village has presented its financial statements under the reporting model pursuant to Governmental Accounting Standards Board Statement No. 34 (GASB 34), *Basic Financial Statements and Management's Discussion and Analysis for State and Local Governments*.

As noted earlier, net assets may serve over time as a useful indicator of a government's financial position. In the case of the Village, assets exceeded liabilities by \$8,525,734 at the close of the most recent fiscal year.

The largest portion of the Village's net assets (83%) reflects its investment in capital assets (e.g., land, buildings, machinery, equipment and infrastructure), less any related debt used to acquire those assets that is still outstanding. The Village uses these capital assets to provide services to citizens; consequentially, these assets are not available for future spending. Although the Village's investment in its capital assets is reported net of related debt, it should be noted that the resources needed to repay this debt must be provided from other sources, since the capital assets themselves cannot be used to liquidate these liabilities. The condensed statement of net assets is as follows:

	Governmental Activities		Business-type Activities		Total	
	March 31, 2009	March 31, 2008	March 31, 2009	March 31, 2008	March 31, 2009	March 31, 2008
Current and other assets	\$ 1,016,788	\$ 819,756	\$ 3,049,867	\$ 2,874,808	\$ 4,066,655	\$ 3,694,564
Capital assets	<u>574,496</u>	<u>661,591</u>	<u>12,074,733</u>	<u>12,590,814</u>	<u>12,649,229</u>	<u>13,252,405</u>
Total assets	<u>1,591,284</u>	<u>1,481,347</u>	<u>15,124,600</u>	<u>15,465,622</u>	<u>16,715,884</u>	<u>16,946,969</u>
Long-term liabilities						
outstanding	1,973,641	2,050,000	5,750,656	5,985,938	7,724,297	8,035,938
Other liabilities	<u>2,708</u>	<u>1,603</u>	<u>463,098</u>	<u>458,359</u>	<u>465,806</u>	<u>459,962</u>
Total liabilities	<u>1,976,349</u>	<u>2,051,603</u>	<u>6,213,754</u>	<u>6,444,297</u>	<u>8,190,103</u>	<u>8,495,900</u>
Net assets:						
Invested in capital assets, net of related debt	570,855	661,591	6,547,392	6,835,646	7,118,247	7,497,237
Restricted	361,841	265,731	-	-	361,841	265,731
Unrestricted	<u>(1,317,761)</u>	<u>(1,497,578)</u>	<u>2,363,407</u>	<u>2,185,679</u>	<u>1,045,646</u>	<u>688,101</u>
Total net assets	<u>\$ (385,065)</u>	<u>\$ (570,256)</u>	<u>\$ 8,910,799</u>	<u>\$ 9,021,325</u>	<u>\$ 8,525,734</u>	<u>\$ 8,451,069</u>

Total net assets increased \$75,000 resulting in a balance of \$8,525,734 as of March 31, 2009. Current assets, which include cash, investments and accounts receivable, increased \$372,000, largely due to a larger receivable balance and cash balances. Non-current assets decreased \$608,000, due to accumulated depreciation and sales of land exceeding the increase in current year additions. Total liabilities decreased \$306,000 resulting in a balance of \$8,190,103 as of March 31, 2009. Outstanding debt, including long-term and short-term portions, decreased \$312,000, due to principle payments on the outstanding bonds. Accounts payable and other accrued expenses increased \$5,800, due to a slight increase in the accounts payable account and customer deposits.

EXPENDITURES BY CATEGORY

Governmental Activities

<u>Expenditures by category</u>	<u>2009</u>		<u>2008</u>	
	<u>Percent</u>	<u>Amount</u>	<u>Percent</u>	<u>Amount</u>
General government	13.4%	\$ 243,994	14.5%	\$ 262,176
Public safety	48.7%	887,469	47.4%	854,139
Highways and streets	24.0%	438,221	24.2%	436,285
Sanitation	9.0%	163,998	8.8%	159,222
Development	0.1%	2,500	0.1%	2,500
Interest on long-term debt	4.8%	87,874	4.9%	87,889
Total expenditures	<u>100.0%</u>	<u>\$1,824,056</u>	<u>100.0%</u>	<u>\$1,802,211</u>

The Village reported increases in expenses for governmental activities of \$22,000. Public safety reported the highest expenditure category with over 48% of all governmental expenditures. The majority of the increase in public safety is associated with salaries and the related benefits.

The above expenditure categories include amounts for depreciation expense on assets purchased in the current and prior years. The breakdown by category is as follows:

	<u>2009</u>	<u>2008</u>
General government	\$ 18,117	\$ 18,117
Public safety	24,503	21,522
Highways and streets	21,129	21,132
Total depreciation	<u>\$ 63,749</u>	<u>\$ 60,771</u>

Total capital outlay expenditures in the governmental fund financial statements for the current year totaled \$41,468.

Business-type Activities

<u>Operating Expenditures</u>	<u>2009</u>		<u>2008</u>	
	<u>Percent</u>	<u>Amount</u>	<u>Percent</u>	<u>Amount</u>
Personal services	20.3%	\$ 1,002,239	20.2%	\$ 979,510
Contractual services	10.1%	502,319	10.8%	522,746
Electricity and water purchased	49.5%	2,451,057	48.9%	2,374,220
Supplies and materials	4.7%	233,595	5.3%	257,071
Heat, light and power	0.4%	18,980	0.4%	17,822
Depreciation	15.0%	740,890	14.6%	707,110
Total expenditures	<u>100.0%</u>	<u>\$ 4,949,080</u>	<u>100.0%</u>	<u>\$ 4,858,479</u>

Expenses in the business-type activities increased in total by \$91,000. As in the prior year, the largest categories of operating expense were for electricity and water purchases which increased \$77,000 in the current year. Personal services increased due to salary increases.

CAPITAL ASSETS AND DEBT ADMINISTRATION

Capital Assets

	<u>Governmental Activities</u>		<u>Business-type Activities</u>		<u>Total</u>	
	<u>March 31, 2009</u>	<u>March 31, 2008</u>	<u>March 31, 2009</u>	<u>March 31, 2008</u>	<u>March 31, 2009</u>	<u>March 31, 2008</u>
Land	\$ 80,406	\$ 145,220	\$ 242,931	\$ 240,867	\$ 323,337	\$ 386,087
Buildings and Improvements	500,284	500,284	6,383,892	6,373,777	6,884,176	6,874,061
Swimming Pool	-	-	109,116	109,116	109,116	109,116
Infrastructure	50,738	50,738	-	-	50,738	50,738
Distribution and Collection Systems	-	-	12,964,532	12,887,720	12,964,532	12,887,720
Vehicles and Equipment	555,534	514,066	1,188,803	1,050,984	1,744,337	1,565,050
	<u>\$ 1,186,962</u>	<u>\$ 1,210,308</u>	<u>\$ 20,889,274</u>	<u>\$ 20,662,464</u>	<u>\$ 22,076,236</u>	<u>\$ 21,872,772</u>

The Village's investment in capital assets for its governmental and business-type activities as of March 31, 2009, amounts to \$12,649,229, net of accumulated depreciation. This investment in capital assets includes land, buildings and improvements, equipment, vehicles and infrastructure. The total outlay for capital assets for the current year was \$268,278. The largest additions in the current year were meters and materials, a Bobcat track loader, several vehicles, and electric line additions. These additions were offset by current year depreciation expense of \$804,639, thereby resulting in a net decrease in net capital assets for the current year. Additional information related to capital assets can be found in Note 6 of the financial statements.

Long-term Debt

At the end of 2009, the Village had total long-term debt obligations for governmental activities and business-type activities in the amount of \$1,973,641 and \$5,750,656, respectively, compared to \$2,050,000 and \$5,985,938 at the end of 2008.

	<u>Governmental Activities</u>		<u>Business-type Activities</u>		<u>Total</u>	
	<u>March 31, 2009</u>	<u>March 31, 2008</u>	<u>March 31, 2009</u>	<u>March 31, 2008</u>	<u>March 31, 2009</u>	<u>March 31, 2008</u>
Loans Payable	\$ -	\$ -	\$ 420,023	\$ 455,938	\$ 420,023	\$ 455,938
Capital Lease	3,641	-	20,633	-	24,274	-
Bonds Payable	1,970,000	2,050,000	5,310,000	5,530,000	7,280,000	7,580,000
Total Debt	<u>\$ 1,973,641</u>	<u>\$ 2,050,000</u>	<u>\$ 5,750,656</u>	<u>\$ 5,985,938</u>	<u>\$ 7,724,297</u>	<u>\$ 8,035,938</u>

The governmental activities reported decreases in long-term debt of \$77,000. The business-type activities reported decreases in long-term debt of \$235,000. All reductions were due to scheduled debt retirements. Additional information related to long-term debt can be found in Note 4 of the financial statements. The Village has no debt that is subject to the debt limit of the Village as calculated by Illinois State Statutes.

VILLAGE OF FREEBURG, ILLINOIS

STATEMENT OF NET ASSETS
 (BUSINESS -TYPE ACTIVITIES - ACCRUAL BASIS)
 (GOVERNMENTAL ACTIVITIES - MODIFIED CASH BASIS)
 MARCH 31, 2009

	<u>Governmental</u> Activities	<u>Business-type</u> Activities	<u>Total</u>
<u>Assets</u>			
Cash and Cash Equivalents	\$ 351,784	\$ 717,142	\$ 1,068,926
Investments	254,608	1,560,656	1,815,264
Receivables (Net of allowance for uncollectible):	-	474,537	474,537
Prepaid Insurance	-	74,217	74,217
Internal Balances	47	(47)	-
Restricted Cash and Cash Equivalents	361,841	-	361,841
Capital Assets:			
Land	80,406	242,931	323,337
Buildings and Improvements	500,284	6,383,892	6,884,176
Swimming Pool	-	109,116	109,116
Infrastructure	50,738	-	50,738
Distribution and Collection Systems	-	12,964,532	12,964,532
Vehicles and Equipment	555,534	1,188,803	1,744,337
Less: Accumulated Depreciation	<u>(612,466)</u>	<u>(8,814,541)</u>	<u>(9,427,007)</u>
Net Capital Assets	<u>574,496</u>	<u>12,074,733</u>	<u>12,649,229</u>
Unamortized Bond Issuance Costs	<u>48,508</u>	<u>223,315</u>	<u>271,823</u>
Total Assets	<u>\$ 1,591,284</u>	<u>\$ 15,124,553</u>	<u>\$ 16,715,837</u>
<u>Liabilities</u>			
Accounts Payable	\$ 2,708	\$ 214,024	\$ 216,732
Accrued Salaries	-	27,859	27,859
Accrued Interest	-	71,666	71,666
Customer Deposits	-	149,549	149,549
Noncurrent Liabilities:			
Due Within One Year	72,710	277,267	349,977
Due In More Than One Year	<u>1,900,931</u>	<u>5,473,389</u>	<u>7,374,320</u>
Total Liabilities	<u>1,976,349</u>	<u>6,213,754</u>	<u>8,190,103</u>
<u>Net Assets</u>			
Invested in Capital Assets, Net of Related Debt	570,855	6,547,392	7,118,247
Restricted	361,841	-	361,841
Unrestricted	<u>(1,317,761)</u>	<u>2,363,407</u>	<u>1,045,646</u>
Total Net Assets	<u>\$ (385,065)</u>	<u>\$ 8,910,799</u>	<u>\$ 8,525,734</u>

The notes to the financial statements are an integral part of this statement

VILLAGE OF FREEBURG, ILLINOIS

STATEMENT OF ASSETS, LIABILITIES AND
FUND BALANCES ARISING FROM MODIFIED CASH BASIS TRANSACTIONS
GOVERNMENTAL FUNDS
MARCH 31, 2009

	General	Other Governmental Funds	Total Governmental Funds
<u>Assets</u>			
Cash and Cash Equivalents	\$ 261,622	\$ 90,162	\$ 351,784
Investments	40,608	214,000	254,608
Due from Other Funds	12,499	-	12,499
Restricted Assets	-	361,841	361,841
Total Assets	\$ 314,729	\$ 666,003	\$ 980,732
<u>Liabilities and Fund Equity</u>			
Liabilities:			
Accounts Payable	\$ 2,708	\$ -	\$ 2,708
Due to Other Funds	-	12,452	12,452
Total Liabilities	2,708	12,452	15,160
Fund Equity:			
Fund Balance:			
Reserved	-	361,841	361,841
Unreserved	312,021	-	312,021
Unreserved, reported in Special Revenue Funds	-	291,710	291,710
Total Fund Balance	312,021	653,551	965,572
Total Liabilities and Fund Equity	\$ 314,729	\$ 666,003	\$ 980,732

The notes to the financial statements are an integral part of this statement

VILLAGE OF FREEBURG, ILLINOIS

STATEMENT OF REVENUES AND EXPENDITURES
ARISING FROM MODIFIED CASH BASIS TRANSACTIONS
GOVERNMENTAL FUNDS
FOR THE YEAR ENDED MARCH 31, 2009

	<u>General</u>	<u>Other Governmental Funds</u>	<u>Total Governmental Funds</u>
Revenues:			
Property Tax	\$ 320,260	\$ 178,876	\$ 499,136
Utility Tax	191,475	-	191,475
Intergovernmental:			
Replacement Tax	5,961	-	5,961
Sales Tax	293,468	84,345	377,813
State Income Tax	359,175	-	359,175
Local Use Tax	56,480	-	56,480
Telecommunications Tax	139,285	-	139,285
Grants	2,295	-	2,295
Motor Fuel Tax	-	102,031	102,031
Franchise Fees	20,560	-	20,560
Licenses and Permits	29,510	-	29,510
Fines and Penalties	15,626	-	15,626
Sale of Supplies	134	-	134
Garbage Collection	173,083	-	173,083
Rental/Lease Income	6,900	-	6,900
Investment Earnings	5,805	11,565	17,370
Miscellaneous	77,227	-	77,227
Total Revenues	<u>1,697,244</u>	<u>376,817</u>	<u>2,074,061</u>
Expenditures:			
Current:			
General Government	225,877	-	225,877
Public Safety:			
Police	860,785	-	860,785
Civil Defense	2,181	-	2,181
Highways and Streets	281,539	135,553	417,092
Development	-	2,500	2,500
Sanitation	163,998	-	163,998
Debt Service:			
Principal	1,759	80,000	81,759
Interest	122	86,381	86,503
Capital Outlay	41,468	-	41,468
Total Expenditures	<u>1,577,729</u>	<u>304,434</u>	<u>1,882,163</u>
Excess of Revenues Over Expenditures	<u>119,515</u>	<u>72,383</u>	<u>191,898</u>
Other Financing Sources (Uses):			
Proceeds from Debt	5,400	-	5,400
Excess of Revenues and Other Financing Sources Over Expenditures	<u>124,915</u>	<u>72,383</u>	<u>197,298</u>
Fund Balance, Beginning of Year	187,106	581,168	768,274
Fund Balance, End of Year	<u>\$ 312,021</u>	<u>\$ 653,551</u>	<u>\$ 965,572</u>

The notes to the financial statements are an integral part of this statement

VILLAGE OF FREEBURG, ILLINOIS

STATEMENT OF NET ASSETS
 PROPRIETARY FUNDS
 MARCH 31, 2009

	<u>Electric Light and Power</u>	<u>Waterworks</u>	<u>Sewer</u>	<u>Non-Major Swimming Pool</u>	<u>Total</u>
<u>Assets</u>					
Current Assets:					
Cash and Cash Equivalents	\$ 388,014	\$ 38,221	\$ 435,999	\$ (145,092)	\$ 717,142
Investments	1,339,000	87,000	134,656	-	1,560,656
Receivables:					
Customers	212,937	37,658	17,886	-	268,481
Unbilled Revenue	143,717	28,760	12,771	-	185,248
Other	1,093	19,715	-	-	20,808
Prepaid Insurance	58,209	8,742	5,783	1,483	74,217
Total Current Assets	<u>2,142,970</u>	<u>220,096</u>	<u>607,095</u>	<u>(143,609)</u>	<u>2,826,552</u>
Noncurrent Assets:					
Property, Plant and Equipment:					
Land	191,676	40,094	4,911	6,250	242,931
Buildings and Improvements	5,406,990	-	919,216	57,686	6,383,892
Swimming Pool	-	-	-	109,116	109,116
Distribution and Collection Systems	8,058,494	3,626,603	1,279,435	-	12,964,532
Vehicles and Equipment	862,255	169,821	137,385	19,342	1,188,803
	<u>14,519,415</u>	<u>3,836,518</u>	<u>2,340,947</u>	<u>192,394</u>	<u>20,889,274</u>
Less - Accumulated Depreciation	5,489,419	2,022,151	1,139,893	163,078	8,814,541
Net Property, Plant and Equipment	<u>9,029,996</u>	<u>1,814,367</u>	<u>1,201,054</u>	<u>29,316</u>	<u>12,074,733</u>
Bond Issuance Costs	223,315	-	-	-	223,315
Total Assets	<u>\$ 11,396,281</u>	<u>\$ 2,034,463</u>	<u>\$ 1,808,149</u>	<u>\$ (114,293)</u>	<u>\$ 15,124,600</u>
<u>Liabilities</u>					
Current Liabilities:					
Accounts Payable	\$ 179,272	\$ 23,587	\$ 11,165	\$ -	\$ 214,024
Accrued Salaries	16,863	6,575	4,421	-	27,859
Due To Other Funds	47	-	-	-	47
Accrued Interest	71,666	-	-	-	71,666
Current Portion of Long Term Debt	227,710	11,730	37,827	-	277,267
Customer Deposits	88,247	36,767	24,535	-	149,549
Total Current Liabilities	<u>583,805</u>	<u>78,659</u>	<u>77,948</u>	<u>-</u>	<u>740,412</u>
Noncurrent Liabilities:					
Long Term Debt (Net of Current)	5,085,931	58,437	329,021	-	5,473,389
Total Noncurrent Liabilities	<u>5,085,931</u>	<u>58,437</u>	<u>329,021</u>	<u>-</u>	<u>5,473,389</u>
Total Liabilities	<u>5,669,736</u>	<u>137,096</u>	<u>406,969</u>	<u>-</u>	<u>6,213,801</u>
<u>Net Assets</u>					
Invested in Capital Assets,					
Net of Related Debt	3,939,670	1,744,200	834,206	29,316	6,547,392
Unreserved	1,786,875	153,167	566,974	(143,609)	2,363,407
Total Net Assets	<u>\$ 5,726,545</u>	<u>\$ 1,897,367</u>	<u>\$ 1,401,180</u>	<u>\$ (114,293)</u>	<u>\$ 8,910,799</u>

The notes to the financial statements are an integral part of this statement

VILLAGE OF FREEBURG, ILLINOIS

STATEMENT OF CASH FLOWS
 PROPRIETARY FUNDS
 FOR THE YEAR ENDED MARCH 31, 2009

	<u>Electric Light and Power</u>	<u>Waterworks</u>	<u>Sewer</u>	<u>Non-Major Swimming Pool</u>	<u>Total</u>
<u>Cash Flows from Operating Activities</u>					
Cash Received from Customers	\$ 3,898,388	\$ 659,675	\$ 321,170	\$ 43,240	\$ 4,922,473
Cash Paid to Suppliers	(2,819,191)	(440,815)	(192,739)	(59,981)	(3,512,726)
Cash Payments to Employees for Services	(348,510)	(169,078)	(144,361)	(29,888)	(691,837)
Net Cash Provided (Used) by Operating Activities	<u>730,687</u>	<u>49,782</u>	<u>(15,930)</u>	<u>(46,629)</u>	<u>717,910</u>
<u>Cash Flows from Capital Financing Activities</u>					
Purchase of Fixed Assets	(119,315)	(59,749)	(47,746)	-	(226,810)
Proceeds from Debt	5,400	12,600	12,600	-	30,600
Principal Paid on Debt	(221,759)	(9,361)	(34,762)	-	(265,882)
Interest Paid on Debt	(222,958)	(1,943)	(9,933)	-	(234,834)
Net Cash Provided (Used) By Capital Financing Activities	<u>(558,632)</u>	<u>(58,453)</u>	<u>(79,841)</u>	<u>-</u>	<u>(696,926)</u>
<u>Cash Flows from Investing Activities</u>					
Interest Income	69,545	5,780	6,792	107	82,224
Net Cash Provided By Investing Activities	<u>69,545</u>	<u>5,780</u>	<u>6,792</u>	<u>107</u>	<u>82,224</u>
<u>Cash Flows from Non-Capital Financing Activities</u>					
Payments From (To) Other Funds	90	-	-	2,529	2,619
Customer Deposits	806	356	779	-	1,941
Net Cash Provided By Non-Capital Financing Activities	<u>896</u>	<u>356</u>	<u>779</u>	<u>2,529</u>	<u>4,560</u>
Net Increase (Decrease) in Cash and Cash Equivalents	242,496	(2,535)	(88,200)	(43,993)	107,768
Cash and Cash Equivalents, Beginning of Year	145,518	40,756	524,199	(101,099)	609,374
Cash and Cash Equivalents, End of Year	<u>\$ 388,014</u>	<u>\$ 38,221</u>	<u>\$ 435,999</u>	<u>\$ (145,092)</u>	<u>\$ 717,142</u>

The notes to the financial statements are an integral part of this statement

VILLAGE OF FREEBURG, ILLINOIS

NOTES TO FINANCIAL STATEMENTS MARCH 31, 2009

NOTE 1: SUMMARY OF SIGNIFICANT ACCOUNTING POLICIES

The financial statements of the Village of Freeburg, Illinois have been prepared in conformity with the modified cash basis of accounting for the Governmental Fund Types and the accrual basis of accounting for the Proprietary Fund Types as applied to government units. The Governmental Accounting Standards Board (GASB) is the accepted standard-setting body for establishing governmental accounting and financial reporting principles. The more significant of the government's accounting policies are described below.

(a) Financial reporting entity

The Village's combined financial statements include the accounts of all Village operations. The criteria for including organizations as component units within the Village's reporting entity, as set forth in Section 2100 of GASB's Codification of Governmental Accounting and Financial Reporting Standards, include whether:

- the organization is legally separate (can sue and be sued in their own name)
- the Village holds the corporate powers of the organization
- the Village appoints a voting majority of the organization's board
- the Village is able to impose its will on the organization
- the organization has the potential to impose a financial benefit/burden on the Village
- there is fiscal dependency by the organization on the Village

The Village has determined that no other outside agency meets the above criteria and therefore, no other agency has been included as a component unit in the Village's financial statements. In addition, the Village is not aware of any entity that would exercise such oversight, which would result in the Village being considered a component unit of the entity.

(b) Government-wide and fund financial statements

The government-wide financial statements (i.e., the statement of net assets and the statement of changes in net assets) report information on all of the nonfiduciary activities of the government. Governmental

VILLAGE OF FREEBURG, ILLINOIS
NOTES TO THE FINANCIAL STATEMENTS (CONTINUED)

The government reports the following major governmental fund:

The General Fund is the Village's primary operating fund. It accounts for all financial resources of the general government, except those required to be accounted for in another fund.

The Village reports the following major proprietary funds:

The Water Fund and the Sewer Fund accounts for all activities related to the billing, administration, distribution and collection processes of the water and sewer utilities. The Village operates the water distribution system as well as the sewage treatment plant, sewage pumping stations and collection systems.

The Electric Light and Power Fund accounts for all activities related to the billing, administration and distribution processes of the Village's electric and power operations.

Private-sector standards of accounting and financial reporting issued prior to December 1, 1989, generally are followed in both the government-wide and proprietary fund financial statements to the extent that those standards do not conflict with or contradict guidance of the Governmental Accounting Standards Board. Governments also have the option of following subsequent private-sector guidance for their business-type activities and enterprise funds, subject to this same limitation. The Village has elected to follow subsequent private-sector guidance. As a general rule, the effect of interfund activity has been eliminated from the government-wide financial statements. Exceptions to this general rule are reimbursements between funds for direct costs applicable to the other fund. Elimination of these charges would distort the direct costs and program revenues reported for the various functions concerned.

Proprietary funds distinguish operating revenues and expenses from nonoperating items. Operating revenues and expenses generally result from providing services and producing and delivering goods in connection with a proprietary fund's principal ongoing operations. The principal operating revenues of the Village's enterprise funds are charges to customers for sales and services. The Village also recognizes as operating revenue the portion of tap fees intended to recover the cost of connecting new customers to the system. Operating expenses for enterprise funds include the cost of sales and services, administrative expenses and depreciation on capital assets. All revenues and expenses not meeting this definition are reported as nonoperating revenues and expenses.

VILLAGE OF FREEBURG, ILLINOIS
NOTES TO THE FINANCIAL STATEMENTS (CONTINUED)

Major outlays for capital assets and improvements are capitalized as projects when constructed. Interest incurred during the construction phase of capital assets of business-type activities is included as part of the capitalized value of the assets constructed.

Property, plant, and equipment are depreciated using the straight line method over the following estimated useful lives:

<u>Type of Property and Equipment</u>	<u>Estimated Useful Lives</u>
Buildings and Improvements	15 – 40 Years
Infrastructure	40 Years
Swimming Pool	20 Years
Distribution and Collection Systems	15 - 50 Years
Vehicles and Equipment	5 - 10 Years

Compensated absences

Sick leave is accrued for all employees at the rate of 1 day per month. On January 1st of the year an employee celebrates their fifth year employment anniversary, and all years thereafter, employees shall be granted twelve sick days. Sick leave can be carried forward, but not to exceed 65 work days. All full-time employees of the Village who have been employed for at least one (1) full year shall become eligible for vacation as indicated by the following table:

<u>Service</u>	<u>Vacation Allowed</u>
Having Completed 1 Year	5 Working Days
2-8 Years Continuous	10 Working Days
9-17 Years Continuous	15 Working Days
18 or More Years Continuous	20 Working Days
	1 day for each year over 18 years of service

An employee separated from the service of the Village shall be compensated for all unused vacation leave accumulated prior to his/her effective date of separation but not for accumulated sick leave. Any liability at March 31, 2009 is immaterial.

VILLAGE OF FREEBURG, ILLINOIS
NOTES TO THE FINANCIAL STATEMENTS (CONTINUED)

NOTE 2: CASH AND CASH EQUIVALENTS AND INVESTMENTS

At March 31, 2009, the carrying amount of the Village's deposits was \$2,739,506 and the bank balance was \$2,738,616. The deposits were comprised of checking, interest checking, money market funds and certificates of deposit.

Custodial Credit Risk. Custodial credit risk is the risk that in the event of a bank failure, the Village's deposits may not be returned to it. As of March 31, 2009, none of the Village's bank balance was exposed to custodial credit risk as uninsured or uncollateralized. Deposits of \$2,337,561 exceeded FDIC coverage but were collateralized by investments held in the Village's name.

At March 31, 2009, the Village had the following investments:

<u>Investment</u>	<u>Weighted Average Maturity (Days)</u>	<u>Fair Value</u>
The Illinois Funds (external investment pool)	Daily	\$ 144,534
Trust Funds	Daily	361,841
Petty Cash		150
Deposits as reported above		<u>2,739,506</u>
Total deposits and investments		<u>\$ 3,246,031</u>
As Reported in the Statement of Net Assets:		
Cash and Cash Equivalents		\$ 1,068,926
Restricted Cash and Cash Equivalents		361,841
Investments		<u>1,815,264</u>
		<u>\$ 3,246,031</u>

Interest Rate Risk. The Village's investment policy limits investment maturities in order to maintain sufficient liquidity to reflect the cash flow needs of the fund type being invested. The Village only maintains investments in the Illinois Funds, which is an external investment pool.

Credit Risk. As of March 31, 2009, the credit rating of the Village's investment was as follows:

<u>Investment</u>	<u>Standard & Poor's Rating</u>	<u>Moody's Investors Service Rating</u>
The Illinois Funds (external investment pool)	AAAm	--

Concentration of Credit Risk. As of March 31, 2009, the Village did not have a concentration of credit risk.

Foreign Currency Risk. As of March 31, 2009, the Village has no foreign currency risk.

VILLAGE OF FREEBURG, ILLINOIS
NOTES TO THE FINANCIAL STATEMENTS (CONTINUED)

of 3% annually. The actuarial value of plan assets was determined using techniques that spread the effects of short-term volatility in the market value of investments over a five-year period with a 20% corridor between the actuarial and market value of assets. The Village's unfunded actuarial accrued liability is being amortized as a level percentage of projected payroll on a closed basis. The remaining amortization period at the December 31, 2006, valuation was 24 years.

Funded Status and Funding Progress. As of December 31, 2008, the most recent actuarial valuation date, the plan was 70.49 percent funded. The actuarial accrued liability for benefits was \$2,808,978 and the actuarial value of assets was \$1,980,186, resulting in an underfunded actuarial accrued liability (UAAL) of \$828,792. The covered payroll (annual payroll of active employees covered by the plan) was \$1,355,164 and the ratio of the UAAL to the covered payroll was 61 percent.

The schedule of funding progress, presented as RSI following the notes to the financial statements, presents multiyear trend information about whether the actuarial value of plan assets is increasing or decreasing over time relative to the actuarial accrued liability for benefits.

(b) Social Security

All employees, including those qualifying for coverage under the Illinois Municipal Retirement Fund, are covered under Social Security. The Village paid \$110,259, the total required contribution for the current fiscal year.

NOTE 4: LONG-TERM DEBT

The Village has the following long-term debt as of March 31, 2009.

Bonds Payable

\$2,050,000 Tax Increment Revenue Bonds, Series 2005 (North State Street Redevelopment Project Area) dated March 17, 2005, due in annual installments of \$30,000 to \$255,000 through November 1, 2024; interest at 4.25% to 5.75%. The amount of bonds outstanding as of March 31, 2009 is \$1,970,000. These bonds are being retired by the TIF Fund.

VILLAGE OF FREEBURG, ILLINOIS
NOTES TO THE FINANCIAL STATEMENTS (CONTINUED)

Annual debt service requirements to maturity for EPA Loans are as follows:

Year Ended April 30,	EPA Loans	
	Principal	Interest
2010	\$ 36,913	\$ 10,877
2011	37,941	9,849
2012	38,996	8,794
2013	40,083	7,707
2014	31,997	7,668
2015 - 2019	172,984	20,341
2020 - 2021	61,110	1,949
	<u>\$ 420,024</u>	<u>\$ 67,185</u>

Capital Lease

\$36,000 capital lease, CitiCapital Commercial Corporation, dated August 8, 2008, for compact track loader, bears interest at 4.62%; monthly principal and interest payments of \$1,567 are due through July 2010. The balance outstanding as of March 31, 2009 is \$24,274. The lease is being retired partially by the the General Fund and by the enterprise funds

Annual debt service requirements for the capital lease are as follows:

Year Ended April 30,	Governmental Activities		Business-type Activities	
	Principal	Interest	Principal	Interest
	2010	\$ 2,710	\$ 111	\$ 15,354
2011	931	9	5,279	51
	<u>\$ 3,641</u>	<u>\$ 120</u>	<u>\$ 20,633</u>	<u>\$ 679</u>

The following is a summary of changes in long-term debt for the year ended March 31, 2009.

	Beginning Balance	Additions	Reductions	Ending Balance	Amounts Due Within One Year
<u>Business-type Activities:</u>					
Bonds Payable	\$ 5,530,000	\$ -	\$ 220,000	\$ 5,310,000	\$ 225,000
Capital Lease	-	30,600	9,967	20,633	15,354
EPA Loans	455,938	-	35,915	420,023	36,913
	<u>\$ 5,985,938</u>	<u>\$ 30,600</u>	<u>\$ 265,882</u>	<u>\$ 5,750,656</u>	<u>\$ 277,267</u>
<u>Governmental Activities:</u>					
Bonds Payable	\$ 2,050,000	\$ -	\$ 80,000	\$ 1,970,000	\$ 70,000
Capital Lease	-	5,400	1,759	3,641	2,710
	<u>\$ 2,050,000</u>	<u>\$ 5,400</u>	<u>\$ 81,759</u>	<u>\$ 1,973,641</u>	<u>\$ 72,710</u>

VILLAGE OF FREEBURG, ILLINOIS
NOTES TO THE FINANCIAL STATEMENTS (CONTINUED)

NOTE 6: CAPITAL ASSETS

Capital asset activity for the year ended March 31, 2009 was as follows:

	<u>Beginning Balance</u>	<u>Increases</u>	<u>Decreases</u>	<u>Ending Balance</u>
<u>Governmental activities:</u>				
Capital assets, not being depreciated:				
Land	\$ 145,220	\$ -	\$ 64,814	\$ 80,406
Capital assets, being depreciated:				
Buildings and improvements	500,284	-	-	500,284
Infrastructure	50,738	-	-	50,738
Vehicles and equipment	<u>514,066</u>	<u>41,468</u>	-	<u>555,534</u>
Total capital assets being depreciated	<u>1,065,088</u>	<u>41,468</u>	-	<u>1,106,556</u>
Less accumulated depreciation for:				
Building and improvements	197,360	13,540	-	210,900
Infrastructure	2,628	1,175	-	3,803
Vehicles and equipment	<u>348,729</u>	<u>49,034</u>	-	<u>397,763</u>
Total accumulated depreciation	<u>548,717</u>	<u>63,749</u>	-	<u>612,466</u>
Total capital assets, being depreciated, net	<u>516,371</u>	<u>(22,281)</u>	-	<u>494,090</u>
Governmental activities capital assets, net	<u>\$ 661,591</u>	<u>\$ (22,281)</u>	<u>\$ 64,814</u>	<u>\$ 574,496</u>
<u>Business-type activities:</u>				
Capital assets, not being depreciated:				
Land	\$ 240,867	\$ 2,064	\$ -	\$ 242,931
Capital assets, being depreciated:				
Buildings and improvements	6,373,777	10,115	-	6,383,892
Swimming pool	109,116	-	-	109,116
Distribution and collection system	12,887,720	76,812	-	12,964,532
Vehicles and equipment	<u>1,050,984</u>	<u>137,819</u>	-	<u>1,188,803</u>
Total capital assets, being depreciated	<u>20,421,597</u>	<u>224,746</u>	-	<u>20,646,343</u>
Less accumulated depreciation for:				
Buildings and improvements	2,757,206	194,754	-	2,951,960
Swimming pool	109,116	-	-	109,116
Distribution and collection system	4,454,542	483,013	-	4,937,555
Vehicles and equipment	<u>752,787</u>	<u>63,123</u>	-	<u>815,910</u>
Total accumulated depreciation	<u>8,073,651</u>	<u>740,890</u>	-	<u>8,814,541</u>
Total capital assets, being depreciated, net	<u>12,347,946</u>	<u>(516,144)</u>	-	<u>11,831,802</u>
Business-type activities capital assets, net	<u>\$ 12,588,813</u>	<u>\$ (514,080)</u>	<u>\$ -</u>	<u>\$ 12,074,733</u>

VILLAGE OF FREEBURG, ILLINOIS

REQUIRED SUPPLEMENTARY INFORMATION
BUDGETARY COMPARISON SCHEDULE
MODIFIED CASH BASIS
GENERAL FUND
FOR THE YEAR ENDED MARCH 31, 2009

	Budgeted Amounts		Actual (Budget Basis)
	Original	Final	
Revenues:			
Property Tax	\$ 463,650	\$ 463,650	\$ 499,136
Replacement Tax	7,300	7,300	5,961
Sales Tax	384,000	384,000	377,813
State Income Tax	384,000	384,000	359,175
Local Use Tax	54,000	54,000	56,480
Telecommunications Tax	142,000	142,000	139,285
Franchise Tax	22,000	22,000	20,560
Utility Tax	200,000	200,000	191,475
Licenses and Permits	52,125	52,125	29,510
Fines and Penalties	18,005	18,005	15,626
Sale of Supplies	205	205	134
Garbage Collection	166,750	166,750	173,083
Rental/Lease Income	6,900	6,900	6,900
Investment Earnings	22,000	22,000	5,805
Grants	2,250	2,250	2,295
Miscellaneous	104,850	104,850	77,227
Total Revenues	<u>2,030,035</u>	<u>2,030,035</u>	<u>1,960,465</u>
Expenditures:			
Current:			
General Government	582,339	582,339	489,098
Public Safety:			
Police	901,848	901,848	860,785
Civil Defense	3,315	3,315	2,181
Highways and Streets	301,211	301,211	281,539
Sanitation	165,650	165,650	163,998
Capital Outlay	64,300	64,300	36,068
Debt Service	-	-	1,881
Total Expenditures	<u>2,018,663</u>	<u>2,018,663</u>	<u>1,835,550</u>
Net Change in Fund Balances	<u>\$ 11,372</u>	<u>\$ 11,372</u>	124,915
No change for modified cash basis reporting			-
As reported on the Statement of Revenues and Expenditures Arising From Modified Cash Basis Transactions			<u>\$ 124,915</u>

VILLAGE OF FREEBURG, ILLINOIS

COMBINING BALANCE SHEET
NONMAJOR SPECIAL REVENUE GOVERNMENTAL FUNDS
MARCH 31, 2009

	<u>Impact Fees</u>	<u>Motor Fuel Tax</u>	<u>TIF</u>	<u>Total</u>
<u>Assets</u>				
Cash and Cash Equivalents	\$ -	\$ 90,162	\$ -	\$ 90,162
Investments	15,000	199,000	-	214,000
Restricted Assets	-	-	361,841	361,841
Total Assets	<u>\$ 15,000</u>	<u>\$ 289,162</u>	<u>\$ 361,841</u>	<u>\$ 666,003</u>
 <u>Liabilities and Fund Balance</u>				
Liabilities:				
Due to Other Funds	<u>\$ -</u>	<u>\$ 12,452</u>	<u>\$ -</u>	<u>\$ 12,452</u>
Total Liabilities	<u>-</u>	<u>12,452</u>	<u>-</u>	<u>12,452</u>
Fund Balance:				
Unreserved	15,000	276,710	-	291,710
Reserved - Debt Service	-	-	361,841	361,841
Total Fund Balance	<u>15,000</u>	<u>276,710</u>	<u>361,841</u>	<u>653,551</u>
Total Liabilities and Fund Balance	<u>\$ 15,000</u>	<u>\$ 289,162</u>	<u>\$ 361,841</u>	<u>\$ 666,003</u>



C. J. SCHLOSSER
& COMPANY, L.L.C.
CERTIFIED PUBLIC ACCOUNTANTS

J. Terry Dooling
David L. Kamler
David M. Bartosiak
Cindy A. Tefeller
Kevin J. Tepen

**INDEPENDENT AUDITOR'S REPORT ON
COMPLIANCE WITH TAX INCREMENT FINANCING ACT**

To the Honorable Mayor and Board
of Trustees of the Village of
Freeburg, Illinois

We have audited the accompanying financial statements of the Village of Freeburg, Illinois for the year ended March 31, 2009, and have issued our report thereon dated November 6, 2009. The financial statements are the responsibility of the Village of Freeburg, Illinois' management. Our responsibility is to express an opinion on the financial statements based on our audit.

Our audit was made in accordance with auditing standards generally accepted in the United States of America. Those standards require that we plan and perform the audit to obtain reasonable assurance about whether the financial statements are free of material misstatement. An audit includes examining, on a test basis, evidence supporting the amounts and disclosures in the financial statements. An audit also includes assessing the accounting principles used and significant estimates made by management, as well as evaluating the overall financial statement presentation. We believe that our audit provides a reasonable basis for our opinion.

The management of the Village of Freeburg, Illinois is responsible for the government's compliance with laws and regulations. In connection with our audit, referred to above, we selected and tested transactions and records to determine the government's compliance with 65 ILCS 5/11-74.4-3, "Tax Increment Allocation Redevelopment Act".

The results of our tests indicate that for the items tested, the Village of Freeburg, Illinois, complied with Subsection (q) of 65 ILCS 5/11-74.4-3, "Tax Increment Allocation Redevelopment Act". Nothing came to our attention that caused us to believe that, for the items not tested, the Village of Freeburg, Illinois was not in compliance with Subsection (q) of 65 ILCS 5/11-74.4-3, "Tax Increment Allocation Redevelopment Act".

C. J. Schlosser & Company, L.L.C.
Certified Public Accountants

November 6, 2009

233 East Center Drive
P.O. Box 416
Alton, Illinois 62002
(618) 465-7717 St. Louis (314) 355-2586
Fax (618) 465-7710



PCPS
THE AICPA ALLIANCE FOR CPA FIRMS
www.cjsco.com

One Westbury Drive
Suite 420
St. Charles, Missouri 63301-2567
(636) 723-7611 St. Louis (636) 947-1008
Fax (636) 947-4558

PROCLAMATION

WHEREAS, the Freeburg Community High School Girl's Volleyball Team, Girl's Cross Country Team, Boy's Cross Country Team and Girl's Golf Team have excelled in the current school year season by reaching State Playoffs; and

WHEREAS, the Freeburg Community High School Girl's Volleyball Team through a determination of purpose to succeed, defeated opponents during the volleyball season to win the 2009 Class 2A State Volleyball Championship; and

WHEREAS, the Freeburg Community High School is a consolidated district composed of the communities and areas of Smithton, St. Libory, Fayetteville, Freeburg; and

WHEREAS, the Village of Freeburg recognizes that the community spirit of such a consolidated school district extends beyond any Village or City limits; and

WHEREAS, the Freeburg Community High School sports teams mentioned above have done more to consolidate this community spirit by their excellence as athletes, true sportsmen and true sportswomen; and

WHEREAS, the students, faculty and staff, parents and fans have assisted in this atmosphere of excellence by example through a genuine display of citizenship in promoting themselves, their school towns as a community committed to the high ideals of life; and

NOW, THEREFORE, I, Raymond S. Danford, Mayor of the Village of Freeburg, do hereby proclaim the day of January 5th as Midget Day.

Given under my hand and seal this 4th day of January, 2010.

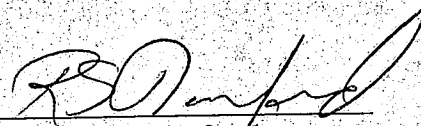

Raymond S. Danford
Mayor

VILLAGE OF FREEBURG

ORDINANCE NO. 1341

AN ORDINANCE ABATING THE TAX HERETO LEVIED FOR THE
YEAR 2009 TO PAY THE PRINCIPAL OF AND INTEREST ON \$5,960,000 GENERAL
OBLIGATION BONDS (ELECTRIC SYSTEM
ALTERNATE REVENUE SOURCE), SERIES 2005, OF THE
VILLAGE OF FREEBURG, ST. CLAIR COUNTY, ILLINOIS

ADOPTED BY THE
VILLAGE PRESIDENT AND BOARD OF TRUSTEES
OF THE
VILLAGE OF FREEBURG
THIS 4th DAY OF JANUARY, 2010

ORDINANCE NO. 1341

AN ORDINANCE ABATING THE TAX HERETO LEVIED FOR THE YEAR 2009 TO PAY THE PRINCIPAL OF AND INTEREST ON \$5,960,000 GENERAL OBLIGATION BONDS (ELECTRIC SYSTEM ALTERNATE REVENUE SOURCE), SERIES 2005, OF THE VILLAGE OF FREEBURG, ST. CLAIR COUNTY, ILLINOIS

WHEREAS, the President and Board of Trustees of the Village (the "Corporate Authorities") of the Village of Freeburg, St. Clair County, Illinois (the "Village"), by Ordinance No. 1202 adopted on the 5th of December, 2005 and a Notification of Sale of Bonds, dated December 7, 2005 (together, the "Ordinance"), did provide for the issue of not to exceed \$7,000,000 General Obligation Bonds (Electric System Alternate Revenue Source), Series 2005 (the "Bonds"), and the levy of a direct annual tax sufficient to pay the principal of and interest on the Bonds; and

WHEREAS, the Pledged Revenues (as defined in the Ordinance) have been determined by the Village Treasurer to provide an amount not less than 1.25 times debt service of all Outstanding Bonds (as defined in the Ordinance) in the next succeeding bond year (June 1st and December 1st); and

WHEREAS, the Revenues have been deposited in the Village of Freeburg 2005 Bond Fund (as created in the Ordinance) in an amount sufficient to pay debt service on all Outstanding Bonds in the next succeeding bond year; and

WHEREAS, it is necessary and in the best interests of the Village that the tax heretofore levied for the year 2009 to pay the principal of and interest on the Bonds be abated.

NOW, THEREFORE BE IT ORDAINED BY THE CORPORATE AUTHORITIES OF THE VILLAGE OF FREEBURG, ST. CLAIR COUNTY, ILLINOIS, AS FOLLOWS:

SECTION 1. Abatement of Tax. The Tax heretofore levied for the year 2009 in the Ordinance is hereby abated in its entirety.

SECTION 2. Filing of Ordinance. Forthwith upon the adoption of this Ordinance, the Village Clerk shall file a certified copy hereof with the County of St. Clair, Illinois, and it shall be the duty of said County Clerk to abate said tax levied for the year 2009 in accordance with the provisions hereof.

SECTION 3. Effective Date. This Ordinance shall be in full force and effect forthwith upon its passage by the Corporate Authorities and signing and approval by the Village President.

PASSED BY THE CORPORATE AUTHORITIES OF THE VILLAGE OF FREEBURG, ILLINOIS, ST. CLAIR COUNTY, AND APPROVED BY THE VILLAGE PRESIDENT THIS 4th DAY OF JANUARY, 2010.

Vote Recorded:

AYES _____

NAYS _____

AYES _____

NAYS _____

AYES _____

NAYS _____

AYES _____

NAYS _____

AYES _____

NAYS _____

AYES _____

NAYS _____

ABSENT _____

ABSTAIN _____

ABSENT _____

ABSTAIN _____

Raymond S. Danford, Village President

ATTEST:

Jerry L. Menard, Village Clerk

Approval as to Legal Form: _____
Stephen R. Wigginton, Village Attorney

CERTIFICATION

I, Jerry Lynn Menard, the duly elected Clerk of the Village of Freeburg certify that the foregoing Ordinance is a true and correct copy of the Ordinance adopted by the Board of Trustees of the Village of Freeburg on January 4, 2010.

Jerry Lynn Menard,
Village Clerk

STATE OF ILLINOIS)
)
COUNTY OF ST. CLAIR) SS

Filing certificate

I, THE UNDERSIGNED, DO HEREBY CERTIFY THAT I AM THE DULY QUALIFIED AND ACTING County Clerk of the County of St. Clair, Illinois, and as such official I do further certify that on the _____ day of _____, 2010, there was filed in my office a duly certified copy of Ordinance No. 1341 entitled:

AN ORDINANCE ABATING THE TAX HERETO LEVIED FOR THE YEAR 2009 TO PAY THE PRINCIPAL OF AND INTEREST ON \$5,960,000 GENERAL OBLIGATION BONDS (ELECTRIC SYSTEM ALTERNATE REVENUE SOURCE), SERIES 2005, OF THE VILLAGE OF FREEBURG, ST. CLAIR COUNTY, ILLINOIS.

(the "Ordinance") duly adopted by the Village Board of Trustees of the Village of Freeburg, St. Clair County, Illinois (the "Village"), on the 4th day of January, 2010, and that the same has been deposited in the official files and records of my office.

I do further certify that the taxes heretofore levied for the year 2009 for the payment of the Village's \$7,000,000 General Obligation Bonds (Electric System Alternate Revenue Source), Series 2005, as described in the Ordinance will be abated in their entirety as provided in the Ordinance.

IN WITNESS WHEREOF I hereunto affix my official signature and the seal of said County this _____ day of _____, 2010.

Bob Delaney, County Clerk

(SEAL)

VILLAGE OF FREEBURG

ORDINANCE NO. 1342

**AN ORDINANCE AUTHORIZING THE EXECUTION OF AN ANNEXATION
AGREEMENT FOR THE ANNEXATION OF 3.0 ACRES, MORE OR LESS, OF
REAL ESTATE OWNED BY RONALD L. WATERS, TRUSTEE SITUATED IN
THE COUNTY OF ST. CLAIR, STATE OF ILLINOIS**

January 4, 2010

Return To:

**Village of Freeburg
14 Southgate Center
Freeburg, IL 62243**

ORDINANCE NO. 1342

AN ORDINANCE AUTHORIZING THE EXECUTION OF AN ANNEXATION AGREEMENT FOR THE ANNEXATION OF 3.0 ACRES, MORE OR LESS, OF REAL ESTATE OWNED BY RONALD L. WATERS, TRUSTEE SITUATED IN THE COUNTY OF ST. CLAIR, STATE OF ILLINOIS

WHEREAS, at least two-thirds (2/3) of the corporate authorities holding office believe it is in the best interest of the Village of Freeburg, St. Clair County, Illinois, to enter into a certain Annexation Agreement pertaining to property consisting of approximately three acres more or less as described in the Annexation Agreement attached as "Exhibit A" and commonly known as the Waters property; and

WHEREAS, an Annexation Agreement has been drafted, a copy of which Agreement is attached hereto and incorporated herein as "Exhibit A;" and

WHEREAS, the Petitioner is described in the Annexation Agreement and/or the legal owner of record of the territory which is the subject of said Agreement are ready, willing and able to enter said Agreement and to perform the obligations as required thereunder; and

WHEREAS, the Village did, on the 4th day of January, 2010, hold and conduct a public hearing pursuant to notice and statute to discuss the Annexation Agreement; and

WHEREAS, all other statutory procedures provided in Division 15.1 of Article II of the Illinois Municipal Code, as amended, for the execution of said Agreement have been fully complied with.

NOW, THEREFORE, BE IT ORDAINED BY THE PRESIDENT AND BOARD OF TRUSTEES OF THE VILLAGE OF FREEBURG, COUNTY OF ST. CLAIR, STATE OF ILLINOIS, as follows:

SECTION 1: The recitals set forth above are true and accurate and incorporated herein by reference.

SECTION 2: That the Village hereby adopts and enters into the Annexation Agreement and the Village President be and he is hereby authorized and directed to execute, and the Village Clerk is directed to attest the Annexation Agreement attached hereto dated the 4th of January, 2010 (a copy of which is attached hereto and made a part hereof as "Exhibit A).

ORDINANCE NO. 1342 cont.

SECTION 3: That this Ordinance shall be in full force and effect from and after its passage, approval, and publication in pamphlet form as provided by law.

PASSED by the Board of Trustees of the Village of Freeburg, Illinois, this 4th day of January, 2010.

AYES _____	NAYS _____	ABSENT _____
AYES _____	NAYS _____	ABSENT _____
AYES _____	NAYS _____	ABSENT _____
AYES _____	NAYS _____	ABSENT _____
AYES _____	NAYS _____	ABSENT _____
AYES _____	NAYS _____	ABSENT _____

Vote recorded by:

Jerry Menard, Village Clerk

Approved by the Village President of the Village of Freeburg, St. Clair County, Illinois, this 4th day of January, 2010.

Raymond S. Danford, Village President

ATTEST:

Jerry Menard, Village Clerk

Approved as to Legal Form:

Stephen R. Wigginton, Village Attorney

ANNEXATION AGREEMENT

THIS ANNEXATION AGREEMENT ("Agreement") is made and entered into this 4th day of January, 2010, by and between Ronald L. Waters, Trustee of the Ronald L. Waters Trust dated 4/25/06, 1109 South State Street, Freeburg, Illinois, (hereinafter referred to as "Owner") and the VILLAGE OF FREEBURG ("Village"), a municipal corporation organization and existing under and by virtue of the laws of the State of Illinois by and through its Mayor and Village Trustees (collectively, "Corporate Authorities").

RECITALS

A. Owner is the owner of record of a certain parcel of real property situated in St. Clair County, Illinois, which is adjacent to the Village and is more particularly described as follows (The Parcel):

Lot 3 of "B.E.K.S. SUBDIVISION"; reference being had to the plat thereof recorded in the Recorder's Office of St. Clair County, Illinois in Book of Plats "89" on page 12.

EXCEPT that portion thereof conveyed by virtue of a Warranty Deed to the People of the State of Illinois dated May 5, 1993 and recorded February 2, 1994 as Document #A01211733 in Book 2961 on page 386.

Excepting coal, oil, gas and other minerals excepted or reserved in prior conveyances, if any.

Situated in the County of St. Clair and the State of Illinois.

P.I.N.: 14-29.0-301-001

Commonly known as: 1109 S. State Street

B. The Parcel adjoins, abuts, and is contiguous to the corporate limits of the Village.

C. The Parcel has not been annexed to any municipality and is currently situated within unincorporated St. Clair County, Illinois.

D. The Parcel constitutes territory that is contiguous to and may be annexed to the Village, as provided under Section 7-1-1, *et seq.*, of the Illinois Municipal Code, 65 ILCS 5/7-1-1, *et seq.*

E. Owner desires to have the Parcel annexed to the Village, on the terms and conditions provided herein and to qualify for such benefits or services as such annexation may so entitle it.

F. The Corporate Authorities, after due and careful consideration, have concluded that the annexation of the Parcel to the Village would further the orderly growth of the Village, enable the Village to control the development of the Parcel, and serve the best interests of the Village.

G. Pursuant to the provisions of 65 ILCS 5/11-15.1-1, *et seq.*, a proposed Annexation Agreement, in substance and form the same as this Agreement, was submitted to the Corporate Authorities and a public hearing was held on January 4, 2010 pursuant to notice, all as provided by statute and the ordinances of the Village.

H. Any fire protection district, library district and other entity or person entitled to notice prior to annexation of the Parcel to the Village has been given notice thereof by the Village as required by law.

NOW, THEREFORE, in consideration of the promises and the mutual covenants and agreements herein contained, and in compliance with ordinances, codes, and regulations of the Village in effect as of the date of this Agreement, or as may hereinafter be enacted, subsequently, the Parties hereto hereby agree as follows:

1. **Statutory Authority.** The Parties hereto enter into this Agreement pursuant to and in accordance with the provisions of 65 ILCS 5/11-15.1-1, *et seq.*

2. **Annexation.**

a) Concurrent with this Agreement, Owner has filed with the Village Clerk a Petition for Annexation of the Parcel to the Village, conditioned on the terms and provisions of this Agreement, which petition has been prepared, executed and filed in accordance with 65 ILCS 5/7-1-8, and the ordinances and other requirements of the Village. A copy of said Petition is attached hereto and made a part hereof as Exhibit "A."

b) Owner has filed with the Village Clerk a Plat of Annexation which contains an accurate map of the Parcel, illustrated with the zoning district(s) Owner is seeking as a condition of annexation, which is attached hereto and made a part hereof as Exhibit "B" ("Annexation Plat").

- c) Subject to the terms of this Agreement, the Corporate Authorities shall hereinafter enact an ordinance annexing the Parcel to the Village ("Annexation Ordinance") which ordinance shall attach the Annexation Plat.

3. Special Use.

- a) This agreement is contingent upon the Zoning Board of Appeals of the Village of Freeburg granting the owner a special use permit to allow the continued operation of his existing glass repair business as a home occupation.
- b) Except as provided herein, all future changes in land use or related activity on the Parcel, if any, shall be subject to the applicable ordinances and laws authorizing or regulating such change or activity now in effect or as amended from time to time.

4. Water Supply/Sanitary Sewer/Electrical Service.

- a) The Village agrees to allow the Owner to connect to the Village water system for the purpose of using said system to serve the owners primary residence only, provided the line construction complies with all standards set by the Village, and Village's Engineer of Record, IEPA, the American Water Works Association Standards of Denver, Colorado as amended from time to time, and/or other state, federal or local regulatory agencies in effect as of the date of this agreement, and further provided the Owner bears all costs related to construction including, but not limited to, cost of labor, material, design and engineering, easement acquisition and tap-in fees. The Village agrees to allow the Owner to connect to the Village sanitary sewer system if it is or becomes available to the parcel provided the Owner bears all costs related to construction including, but not limited to, cost of labor, material, design and engineering, easement acquisition and tap-in fees. The Village agrees to allow the Owner to connect to the Village electric system upon request, however, since Owner has already connected to electric service provided by Ameren, any charges due Ameren for disconnecting their service shall be at Owner's expense.

5. Dedication of Improvements.

- a) In the event the Owner subdivides or otherwise develops the Parcel, the Owner shall dedicate to the Village, the roadways, the public improvements, the water lines, sanitary sewers and the storm sewers by recording with the St. Clair County, Illinois Recorder, in a form acceptable to the Village, the appropriate subdivision plat which dedicates the public improvements as

provided herein. Nothing herein shall require the Village to accept such improvements for maintenance or liability that are not in satisfaction of the Village's specifications or that have not been inspected by the Village, approved and accepted by the Village.

- b) The Owner shall grant to the Village nonexclusive utility easements ("Utility Easements") for maintenance and repair of the aforesaid utilities to be constructed on the Parcel and dedicated to the Village as shown on the Final Plat, and any other easements the Village may reasonably require for municipal purposes.

6. **Development Fees.** Owner shall pay all development fees including but not limited to green space fees, plat review fees, completion and maintenance security for dedicated public improvements and normal and customary building permits, relative to development of the Parcel as set forth in the Code of Ordinances of the Village of Freeburg, as amended from time to time.

7. **Miscellaneous.**

- a) Notwithstanding any other provision contained herein to the contrary, with respect to the Parcel, this Agreement shall be effective for a term of twenty (20) years from the date hereof, provided that any continuing obligations to the Village shall survive any termination or expiration to the extent consistent with 65 ILCS 5/11-15.1-1.
- b) This Agreement shall bind the heirs, successors, and assigns of the Owner, the Village, the Corporate Authorities and their successors in office. This Agreement shall inure to the benefit of the Parties hereof, their successors and assigns.
- c) This Agreement and the obligations of Owner hereunder shall be a covenant that shall run with the land, shall be a provision of any sale or other contract for transfer of interest in the Parcel, and may be recorded. Upon annexation, Owner shall comply with all ordinances of the Village, as adopted or amended from time to time.
- d) Nothing herein shall in any way prevent the alienation, encumbrance or sale of the Parcel or any portion thereof, and the new owner or owners shall be both benefited and bound by the conditions and restrictions herein expressed.
- e) Within thirty (30) days after the passage, approval and adoption of an ordinance of annexation by the Village, the text of this Agreement (or a suitable memorandum hereof) shall be recorded at the sole cost and expense of the Village in the Office of the Recorder of St. Clair County, Illinois.
- f) It is further agreed that any party to this Agreement, either in law or in equity, by suit, action, mandamus or other proceeding may enforce or compel the performance of this Agreement, or have other such relief for the breach

thereof as may be authorized by law or that by law or in equity is available to them.

- g) It is understood by the Parties hereto that time is of the essence. It is further understood that upon the occurrence of a default of any of the provisions of this Agreement, which default continues for ten (10) days after a notice specifying such default is given the defaulting party, the injured party hereto may in law or in equity, by suit, action, mandamus or other proceeding, including specific performance, enforce or compel the performance of this Agreement by such defaulting party.
- h) The undersigned persons, whether signing individually, on behalf of a municipal corporation, or by an attorney-in-fact warrant themselves: (i) to be of lawful age, (ii) to be legally competent to execute this Agreement, (iii) to be fully authorized to execute this Agreement on behalf of themselves or the municipal corporation or other entity indicated below, and (iv) to have signed this Agreement on their own behalf or on behalf of such municipal corporation or other entity as their own free acts and deeds and/or the free acts and deeds of such municipal corporation or other entity after opportunity to consult with legal counsel.
- i) In the event any portion of this Agreement or part thereof shall be deemed invalid, such invalidity of said provision or part thereof shall not affect the validity of any other provision hereof.
- j) Unless stated otherwise herein, any notice required or permitted under this Agreement shall be in writing and shall be deemed given when mailed by registered or certified mail, return receipt requested, to the respective parties at their addresses listed below:

If to the Village:

Village of Freeburg, Illinois
Freeburg Municipal Center
14 Southgate Center
Freeburg, IL 62243
Attention: Mayor

With a copy to:

Mr. Stephen R. Wigginton, Esq.
Weilmuenster & Wigginton, P.C.
3201 W. Main Street
Belleville, IL 62226

If to the Owner:

Ronald L. Waters
1109 South State St.
Freeburg, IL 62243

IN WITNESS WHEREOF, the Parties hereto have caused this Agreement to be executed as of the day and year first above written.

VILLAGE:

VILLAGE OF FREEBURG
A Municipal Corporation,
County of St. Clair
State of Illinois

ATTEST:

Jerry Menard
Village Clerk

Raymond S. Danford
Village President

OWNERS:

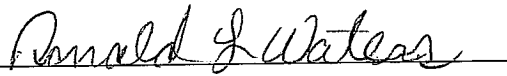

Ronald L. Waters

LIST OF EXHIBITS

- A. Petition for Annexation
- B. Annexation Plat

PETITION FOR ANNEXATION

To: The Mayor and Board of Trustees
Of the Village of Freeburg,
St. Clair County, Illinois

The Petitioner, Ronald L. Waters, Trustee of the Ronald L. Waters Trust dated 4/25/06 states under oath:

1. Petitioner is the sole legal and equitable owner of record of the following described land (hereinafter sometimes referred to as the "Tract"), to-wit:

Lot 3 of "B.E.K.S. SUBDIVISION"; reference being had to the plat thereof recorded in the Recorder's Office of St. Clair County, Illinois in Book of Plats "89" on page 12.

EXCEPT that portion thereof conveyed by virtue of a Warranty Deed to the People of the State of Illinois dated May 5, 1993 and recorded February 2, 1994 as Document #A01211733 in Book 2961 on page 386.

Excepting coal, oil, gas and other minerals excepted or reserved in prior conveyances, if any.

Situated in the County of St. Clair and the State of Illinois.

P.I.N.: 14-29.0-301-001

2. The tract is not situated within the limits of any municipality, but is contiguous to the Village of Freeburg.

3. That Petitioner represents at least 51% of electors residing on the tract.

4. It is the desire of the Petitioner and it would be in the best interest of the Village of Freeburg, Illinois, that said tract be annexed to the Village of Freeburg, Illinois and made a part thereof, with the zoning classification of SR-1.

WHEREFORE PETITIONER RESPECTFULLY REQUESTS:

1. That the above described tract be annexed to the Village of Freeburg by ordinance of the President and Board of Trustees of the Village of Freeburg pursuant to Section 7-1-8 of the Illinois Municipal Code of the State of Illinois as amended (65 ILCS 5/6-1-8).
2. That such other action be taken as is appropriate in the premises.



Ronald L. Waters

Dated this 30th day of November, 2009.

Subscribed to and sworn to before me this 30th day of November, 2009.

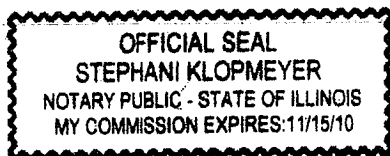

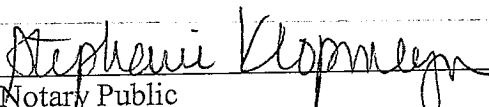

Notary Public

ANNEXATION PLAT ORDINANCE NO. 1342 FREEBURG, ILLINOIS

PART OF THE S.W. 1/4 OF THE S.W. 1/4 SECTION 29
T. 1 S., R. 7 W. OF THE 3RD P.M.
ST. CLAIR COUNTY, ILLINOIS

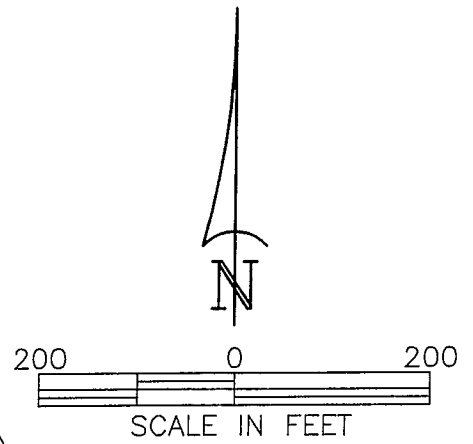
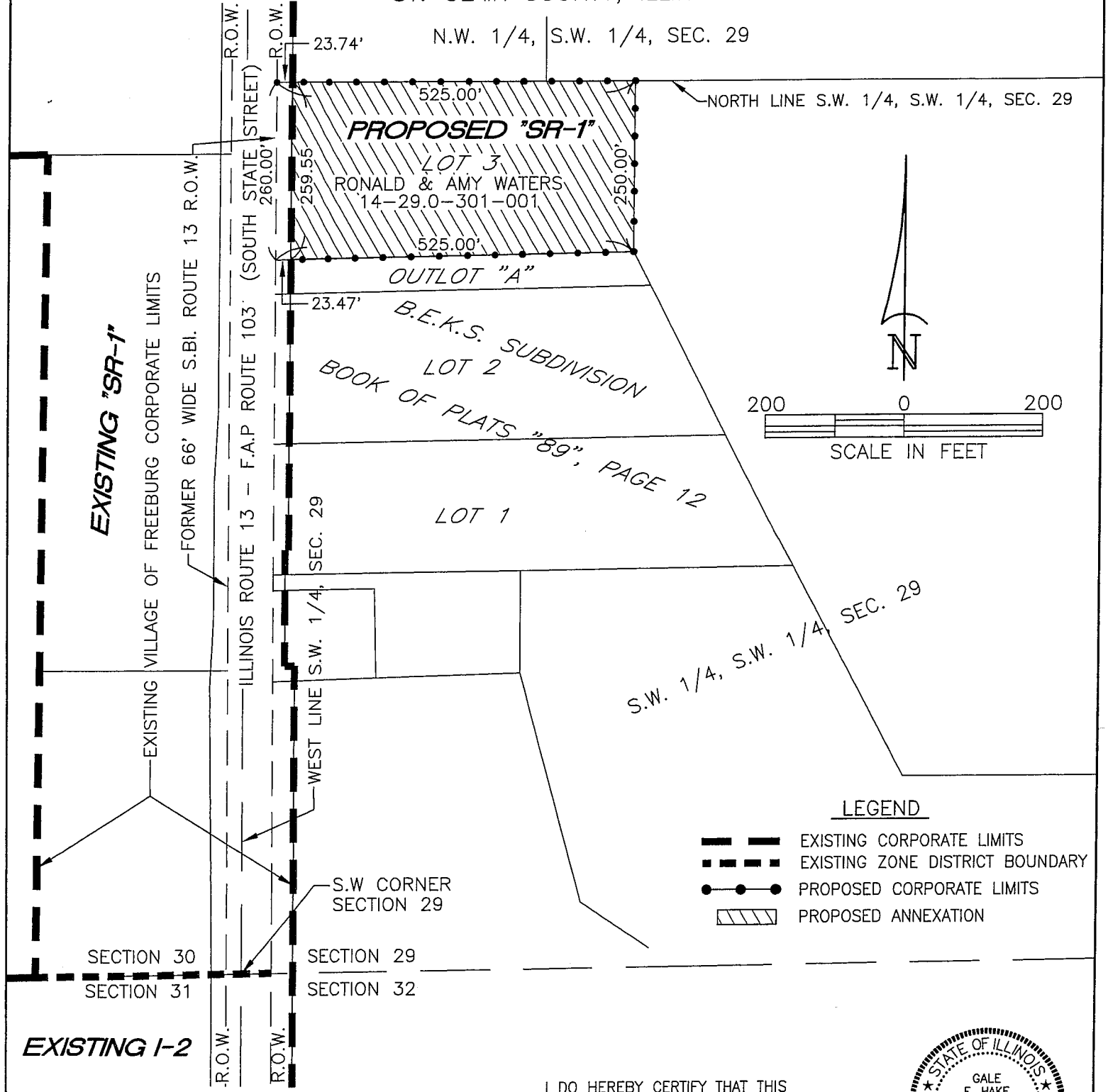

LEGEND

- EXISTING CORPORATE LIMITS
- EXISTING ZONE DISTRICT BOUNDARY
- PROPOSED CORPORATE LIMITS
- PROPOSED ANNEXATION

EXISTING I-2



RHUTASEL and ASSOCIATES, INC.
 CONSULTING ENGINEERS • LAND SURVEYORS
 FREEBURG, ILLINOIS CENTRALIA, ILLINOIS
 (618) 539-3178 (618) 532-1992
 I.L. LICENSE NO. 184-000287

I DO HEREBY CERTIFY THAT THIS
 ANNEXATION PLAT HAS BEEN PREPARED
 UNDER MY DIRECT SUPERVISION

Gale E. Hake 12/14/09
 GALE E. HAKE, I.P.L.S. NO. 2579 DATE
 LICENSE EXPIRATION DATE: 11/30/2010



PETITION FOR ANNEXATION)
OF TERRITORY KNOWN AS THE)
WATERS PROPERTY,)
1109 S. STATE STREET)
TO THE VILLAGE) ORDINANCE NO. 1342
OF FREEBURG, ILLINOIS)

AFFIDAVIT

STATE OF ILLINOIS)
) ss.
COUNTY OF ST. CLAIR)

Affiant, STEPHEN R. WIGGINTON, being first duly sworn on his oath, states:

1. That he is the attorney of record for the Village of Freeburg, Illinois.
2. That the territory sought to be annexed and fully described in Exhibit "A" lies within the following fire protection district: Freeburg Fire Protection District.

3. That on December 15, 2009, Affiant sent notices in writing by certified mail to the following Freeburg Board of Township Trustees:

Roger Rubemeyer, 32 Lakeview Drive, Freeburg, IL 62243
Marianne E. Recker, 8960 Jacks Run Road, Freeburg, IL 62243
William Burgert, 111 E. St. Clair, Freeburg, IL 62243
Kenneth Bald, 568 Cemetery Road, Freeburg, IL 62243

4. That on December 15, 2009, Affiant sent a notice in writing by certified mail to the Township Supervisor: Charles H. Hill, 405 N. Edison, Freeburg, IL 62243;

5. That on December 15, 2009, Affiant sent a notice in writing by certified mail to the Township Clerk: Herbert J. Vollmer, 301 E. Mill Street, Freeburg, IL 62243;

6. That on December 15, 2009, Affiant sent a notice in writing by certified mail to the Township Highway Commissioner: Dale A. Recker, 8942 Jacks Run Road, Freeburg, IL 62243;

7. That on December 15, 2009, Affiant sent a notice in writing by certified mail to

the St. Clair County Highway Department: 1415 N. Belt West, Belleville, IL 62226;

8. That on December 15, 2009, Affiant sent a notice in writing by certified mail to the Freeburg Area Library: 407 S. Belleville, Freeburg, IL 62243;

9. That on December 15, 2009, Affiant sent a notice in writing by certified mail to the Freeburg Fire Protection District: 410 W. High Street, Freeburg, IL 62243;

10. That receipts were returned to Affiant showing delivery of notices to Herbert Vollmer, Dale Recker, Kenneth Bald, Marianne Recker, Roger Rubemeyer, St. Clair County Highway Department and Freeburg Fire Protection District on December 16, 2009.

8. That receipts were returned to Affiant showing delivery of notices to William Burgett and Freeburg Area Library on December 17, 2009.

9. That a receipt was returned to Affiant showing delivery of notice to Charles Hill with no date annotated.

Further Affiant sayeth naught.

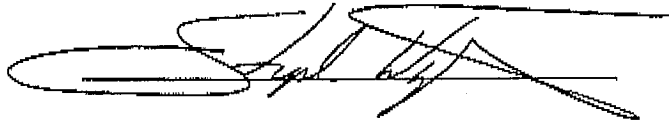

Stephen R. Wigginton

Subscribed and sworn to before me this 30th day of December, 2009.



Notary Public



ORDINANCE NO. 1343

**AN ORDINANCE ANNEXING CERTAIN TERRITORY TO THE VILLAGE
OF FREEBURG, ST. CLAIR COUNTY, ILLINOIS
(WATERS PROPERTY, 1109 S. STATE STREET, FREEBURG)**

WHEREAS, a written petition, signed by the legal owner of record of all land within the territory hereinafter described, has been filed with the Village Clerk of the Village of Freeburg, St. Clair County, Illinois, requesting that said territory be annexed to the Village of Freeburg, and,

WHEREAS, petitioner is the sole elector residing within the said territory; and,

WHEREAS, the said territory is not within the corporate limits of any municipality but is contiguous to the Village of Freeburg; and

WHEREAS, legal notices regarding the intention of the Village to annex said territory have been sent to all public bodies required to receive such notice by state statute; and,

WHEREAS copies of such notices required to be recorded, if any, have been recorded in the Office of the Recorder of St. Clair County; and,

WHEREAS, all petitions, documents, and other necessary legal requirements are in full compliance with the statutes of the State of Illinois, specifically Section 7-1-8 of the Illinois Municipal Code; and,

WHEREAS, it is in the best interest of the Village of Freeburg that the territory be annexed thereto.

NOW, therefore, be it ordained by the President and Board of Trustees of the Village of Freeburg, St. Clair County, Illinois, as follows:

ORDINANCE NO. 1343 cont.

Section 1: THAT the following described territory,

Lot 3 of "B.E.K.S. SUBDIVISION"; reference being had to the plat thereof recorded in the Recorder's Office of St. Clair County, Illinois in Book of Plats "89" on page 12.

EXCEPT that portion thereof conveyed by virtue of a Warranty Deed to the People of the State of Illinois dated May 5, 1993 and recorded February 2, 1994 as Document #A01211733 in Book 2961 on page 386.

Excepting coal, oil, gas and other minerals excepted or reserved in prior conveyances, if any.

Situated in the County of St. Clair and the State of Illinois.

P.I.N.: 14-29.0-301-001

Commonly known as: 1109 S. State Street

being indicated on an accurate map of the annexed territory (which is appended to and made part of this Ordinance) is hereby annexed to the Village of Freeburg, St. Clair County, Illinois, with a zoning classification of SR-1 (Single Family Residential).

Section 2: THAT the Village Clerk is hereby directed to record with the Recorder and to file with the County Clerk a certified copy of this Ordinance, together with the accurate map of the territory annexed appended to the Ordinance.

Section 3: THAT this Ordinance shall be in full force and effect from and after its passage, approval, and publication in pamphlet form as provided by law.

AYES _____	NAYS _____	ABSENT _____
AYES _____	NAYS _____	ABSENT _____
AYES _____	NAYS _____	ABSENT _____
AYES _____	NAYS _____	ABSENT _____
AYES _____	NAYS _____	ABSENT _____
AYES _____	NAYS _____	ABSENT _____

Vote recorded by:

Jerry Menard, Village Clerk

ORDINANCE NO. 1343 cont.

Approved by the Village President of the Village of Freeburg, St. Clair County, Illinois,
this 4th day of January, 2010.

Raymond S. Danford, Village President

ATTEST:

Jerry Menard, Village Clerk

Approved as to Legal Form: _____
Stephen R. Wigginton, Village Attorney

ANNEXATION PLAT ORDINANCE NO. 1343 FREEBURG, ILLINOIS

PART OF THE S.W. 1/4 OF THE S.W. 1/4 SECTION 29
T. 1 S., R. 7 W. OF THE 3RD P.M.
ST. CLAIR COUNTY, ILLINOIS

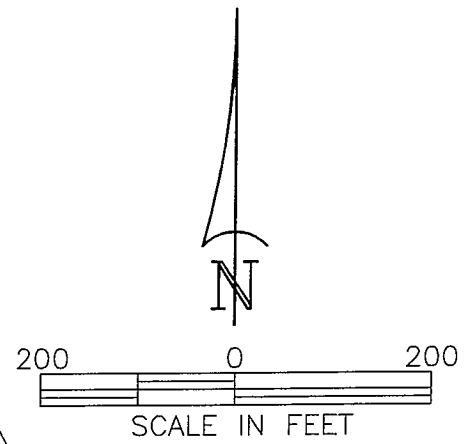
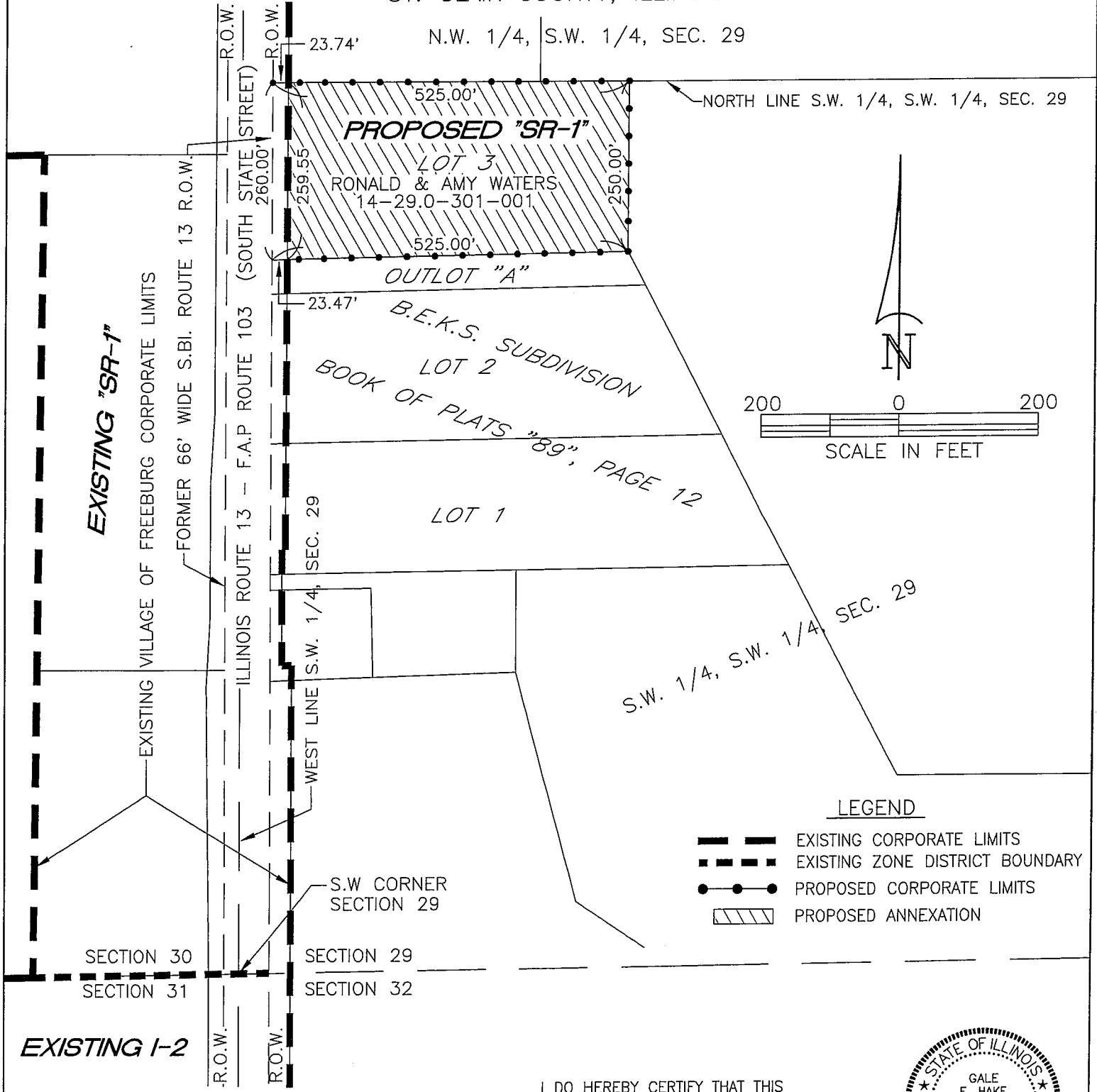

LEGEND

- EXISTING CORPORATE LIMITS
- EXISTING ZONE DISTRICT BOUNDARY
- PROPOSED CORPORATE LIMITS
- PROPOSED ANNEXATION

EXISTING I-2



RHUTASEL and ASSOCIATES, INC.
 CONSULTING ENGINEERS • LAND SURVEYORS
 FREEBURG, ILLINOIS CENTRALIA, ILLINOIS
 (618) 539-3178 (618) 532-1992
 IL. LICENSE NO. 184-000287

I DO HEREBY CERTIFY THAT THIS
 ANNEXATION PLAT HAS BEEN PREPARED
 UNDER MY DIRECT SUPERVISION

Gale E Hake 12/14/09
 GALE E. HAKE, I.P.L.S. NO. 2579 DATE
 LICENSE EXPIRATION DATE: 11/30/2010

